

2007-2013 Toyota Tundra Audio Upgrade Complete Installation Manual

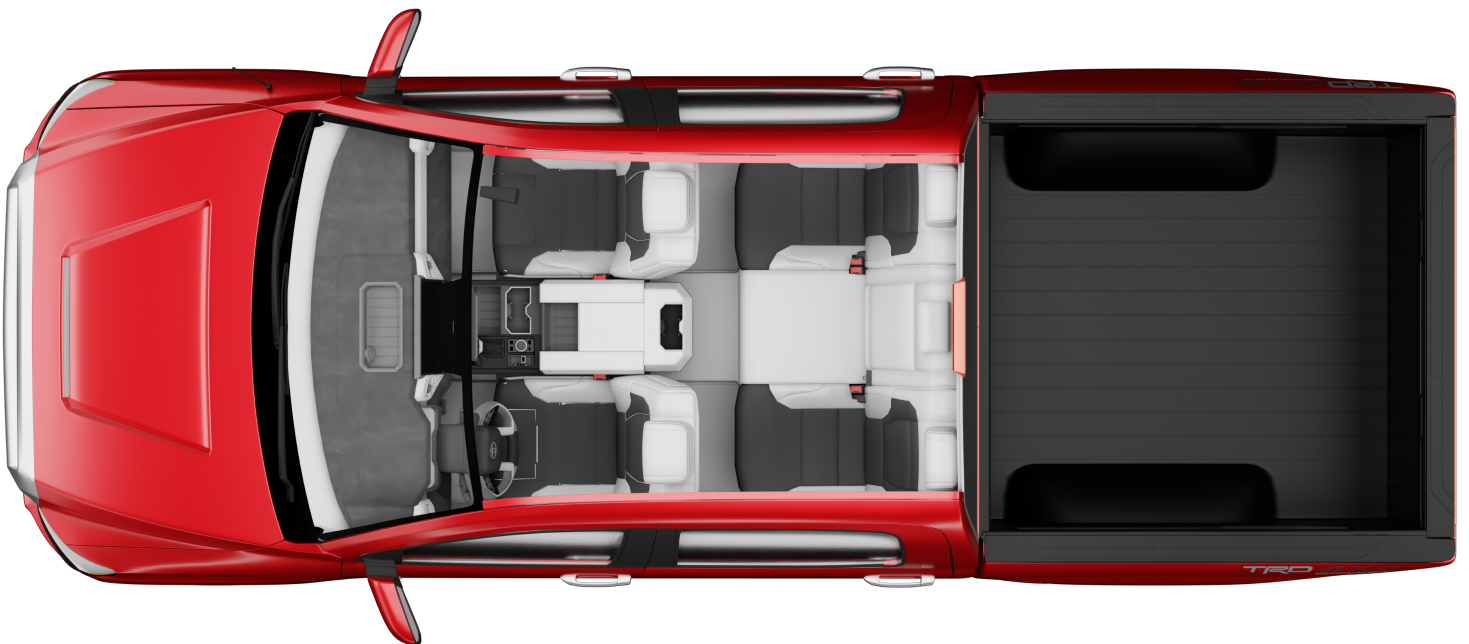

SYSTEM 1B



PLUG & PLAY INTEGRATION OVERVIEW

4G Power Wire
runs from
battery to TXD
Amplifiers

**Connect to factory
wiring & Head Unit,**
and run to TXD
Amplifiers:

Plug & play harness 1
Plug & play harness 2

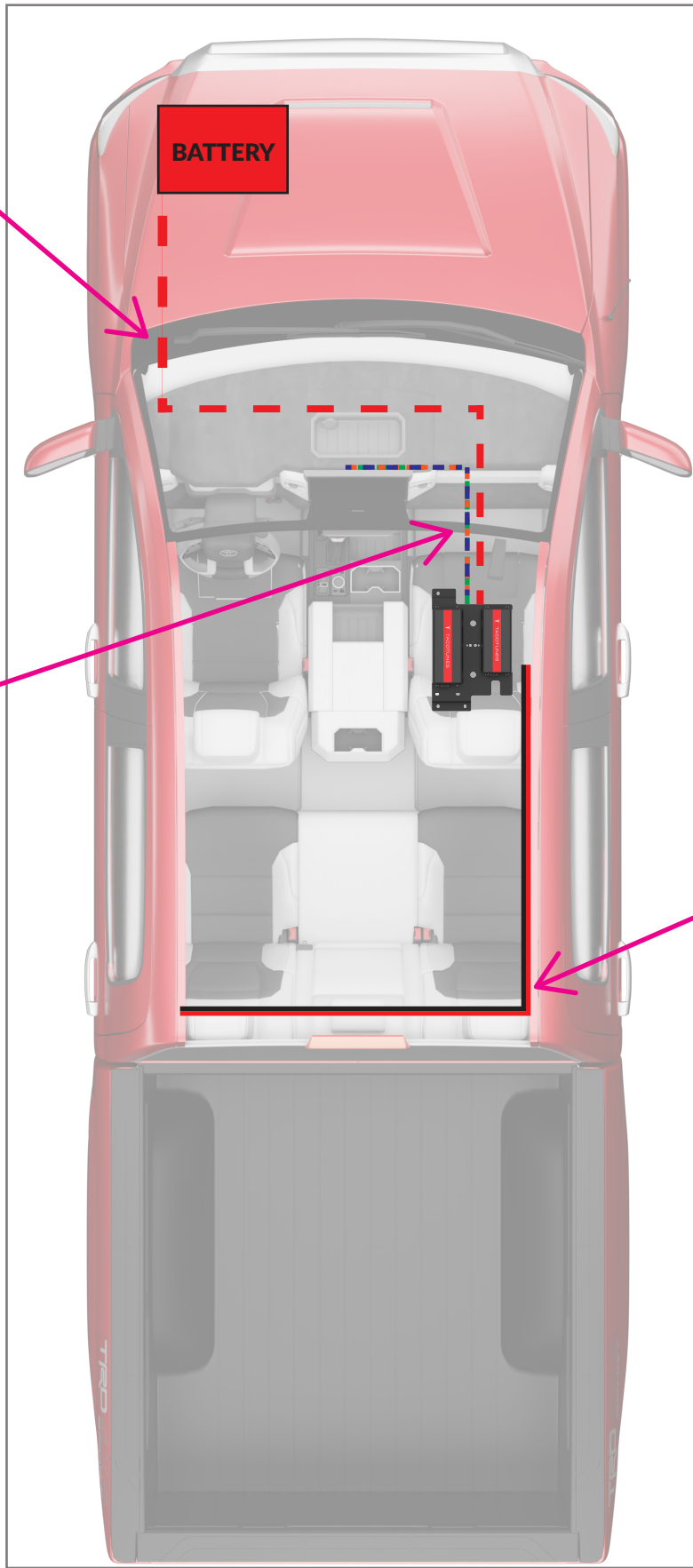

**12 Gauge
subwoofer wire**
ran from
TXD1000.1 to
behind rear seat

SECTION 1 -

Plug and Play Harness Integration

NO FACTORY AMP UNDER SEAT

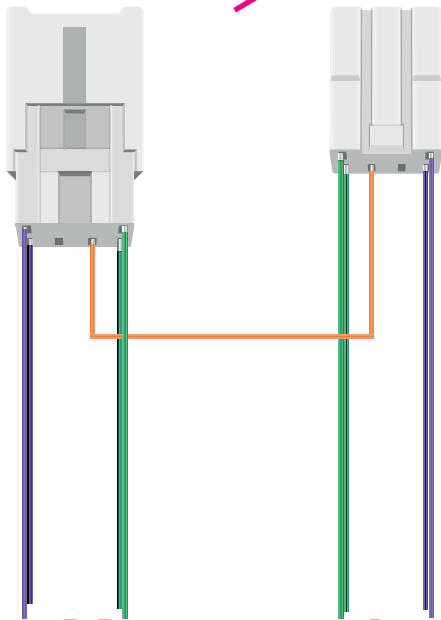
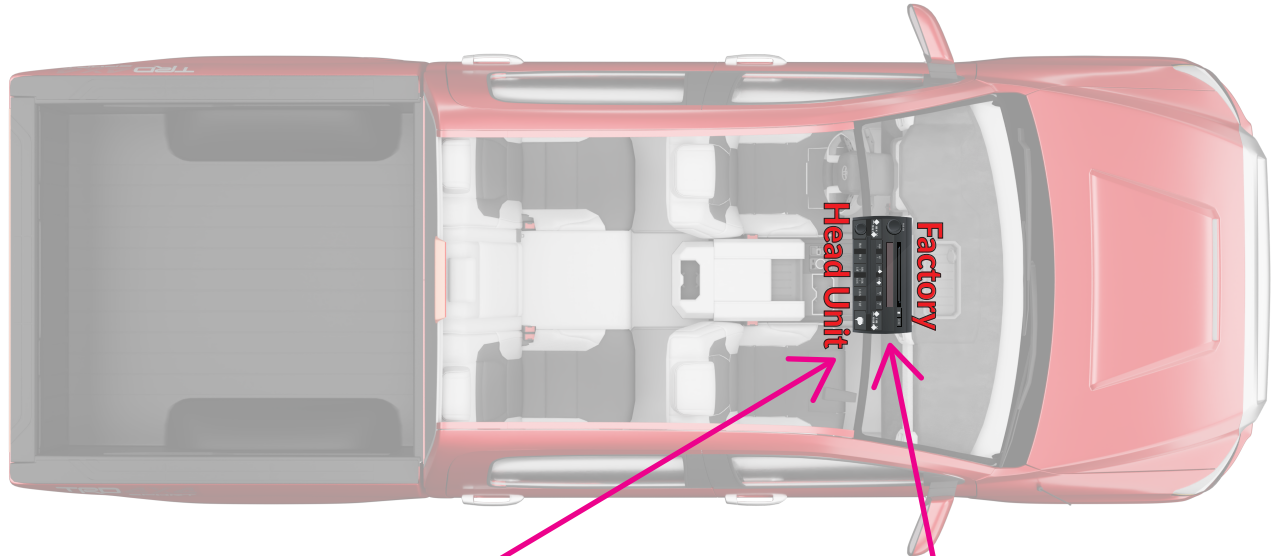

Harness 1

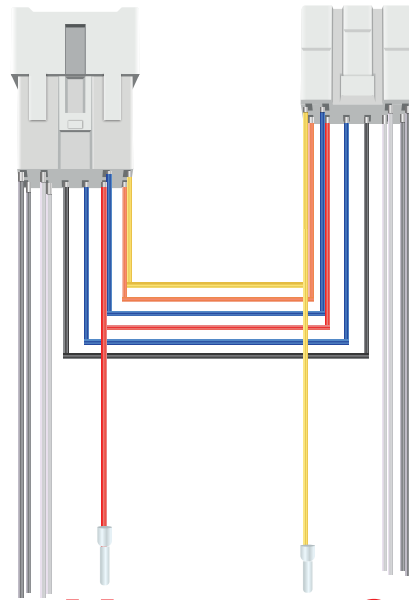

Harness 2

Harness 1 & 2 plug directly into the back of your factory head unit and dash wiring.

Install these harnesses according steps on the following pages

SECTION 1a -

REMOVE FACTORY AMP

Remove Factory Head Unit

Take photo of head unit connections for reference when re-installing

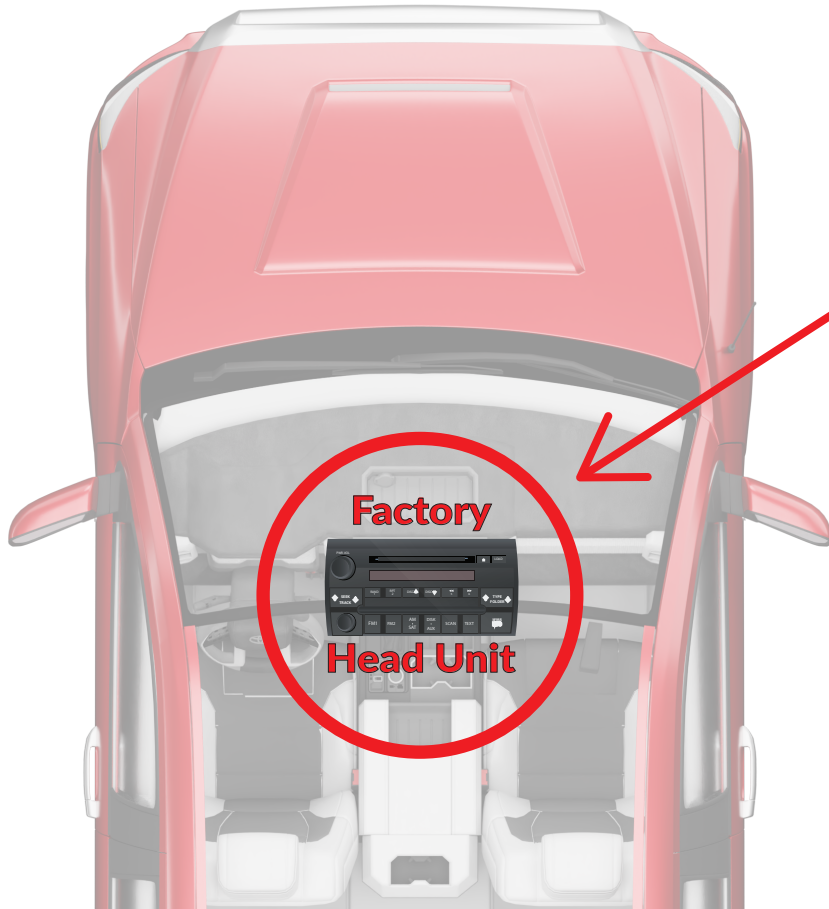

Plug and Play harnesses connect to 10 & 6 pin connections

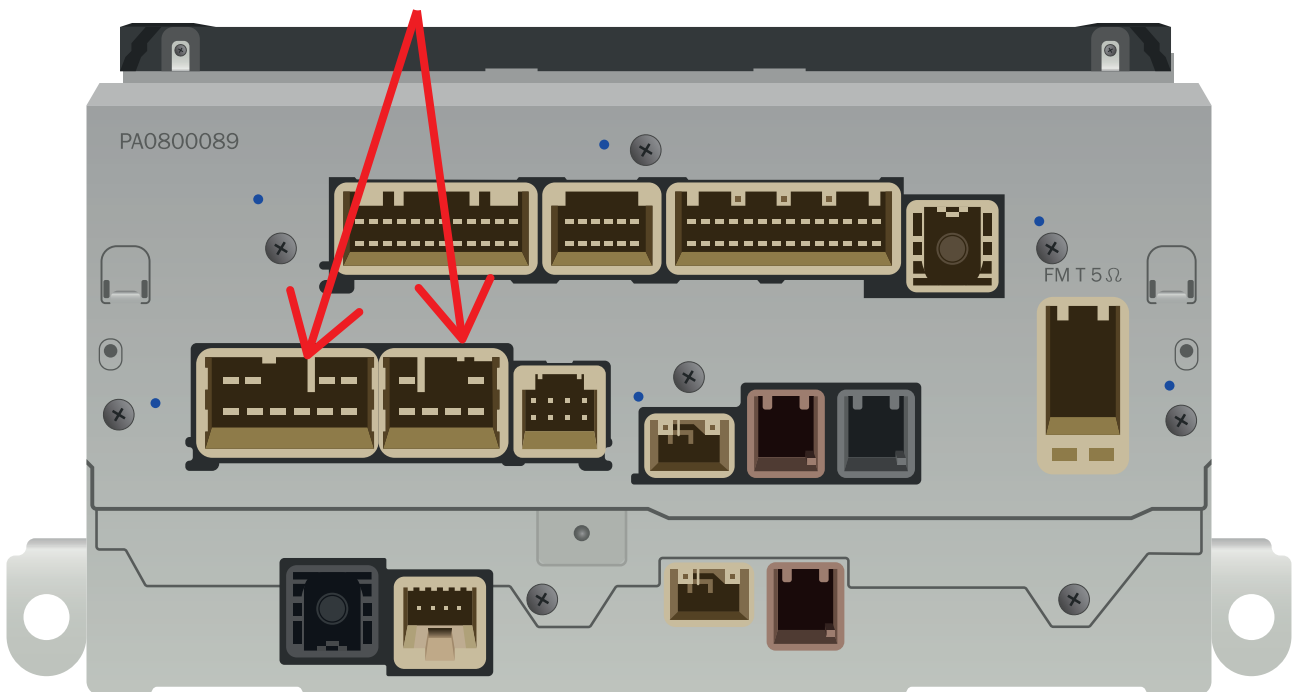

SECTION 1b -

CONNECT PLUG AND PLAY WIRING

Stock Wiring
(Inside dashboard)

Stock Wiring
(Inside dashboard)

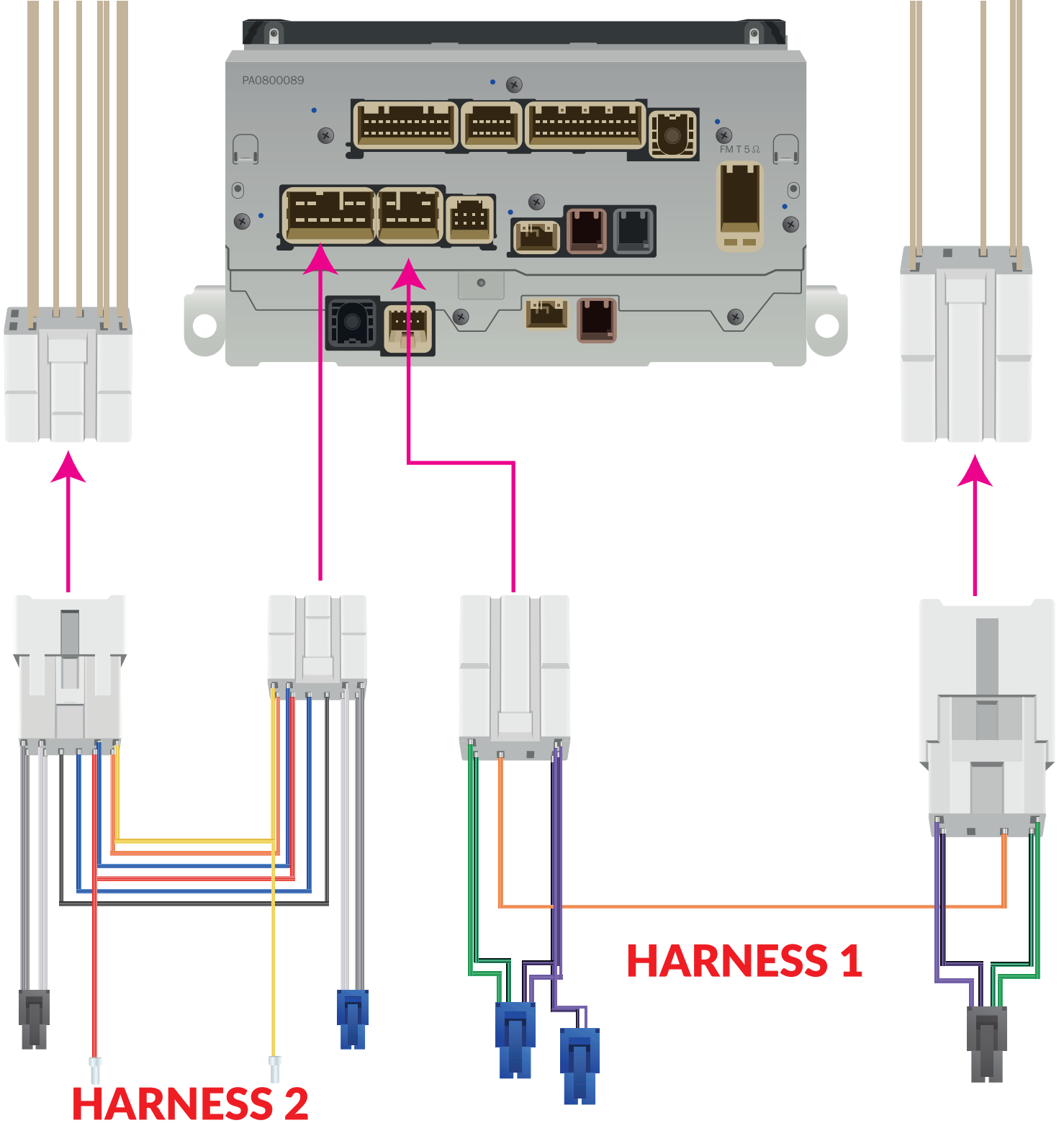

Harness 1

Blue Molex Plug Connections

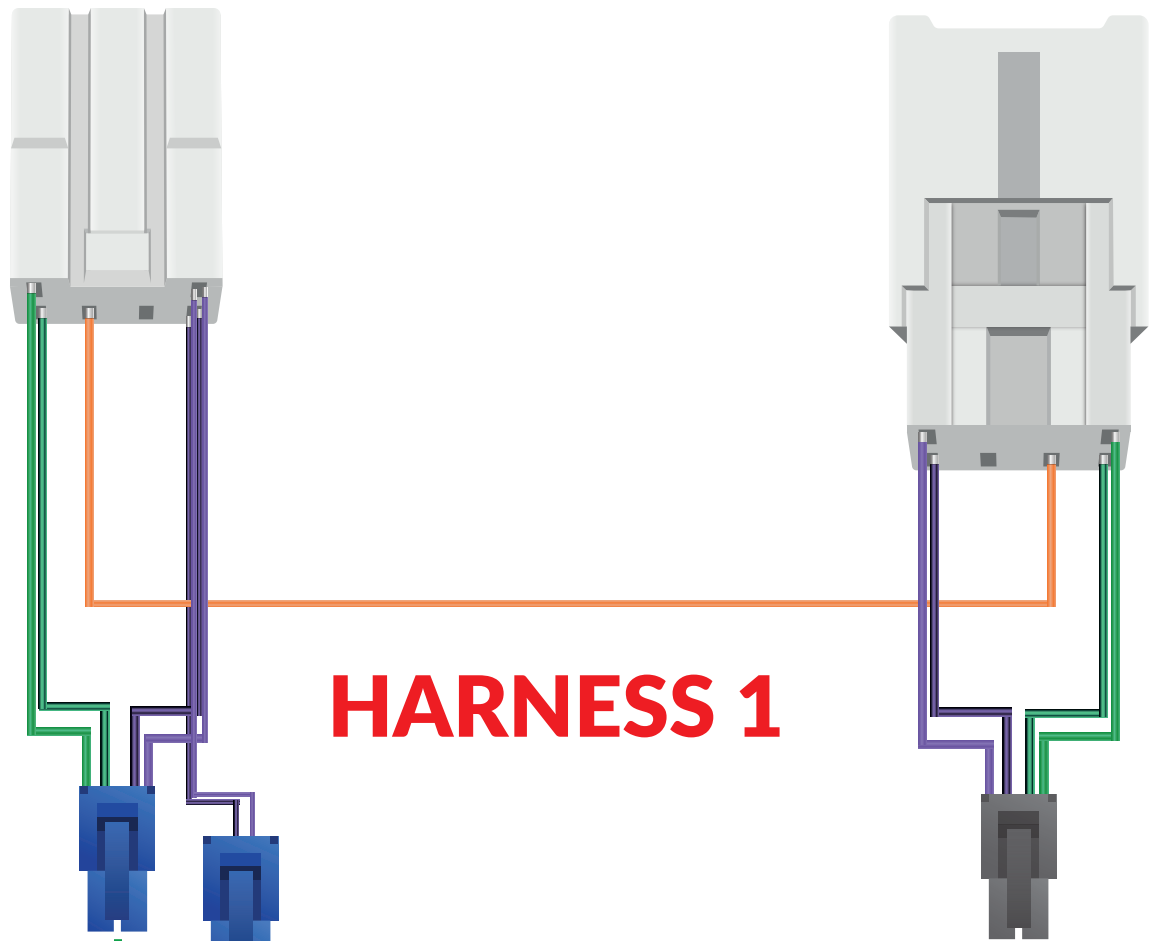

HARNESS 1



Harness 2

Blue Molex Plug Connections

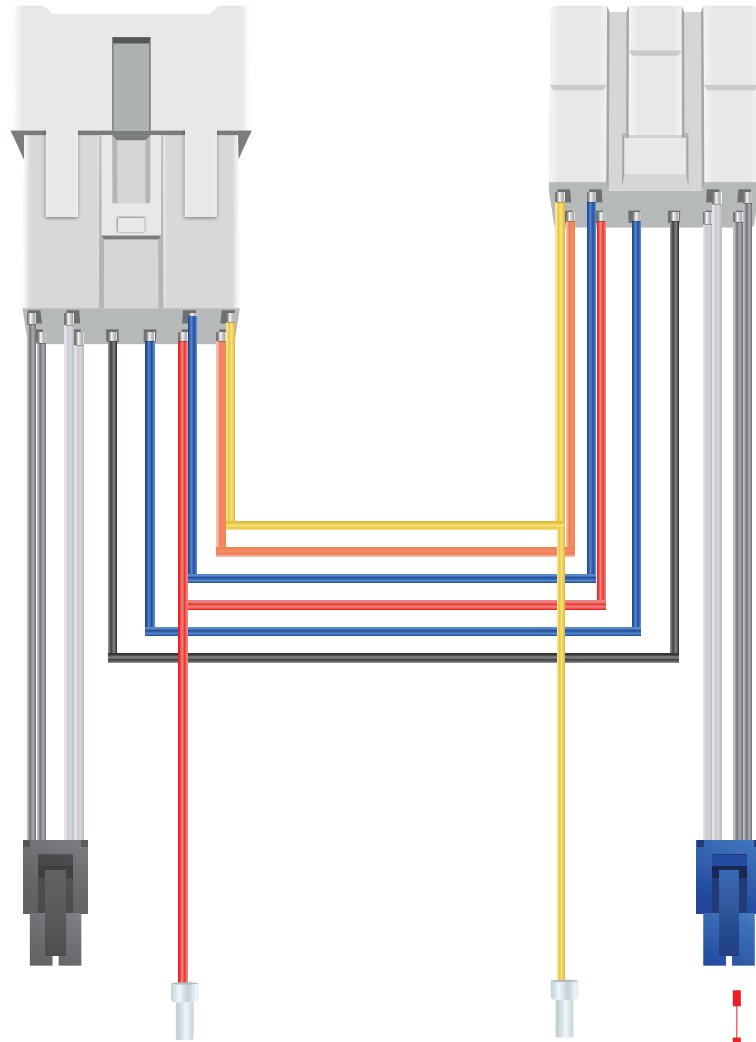

Harness 2



Harness 1

Black Molex Plug Connections

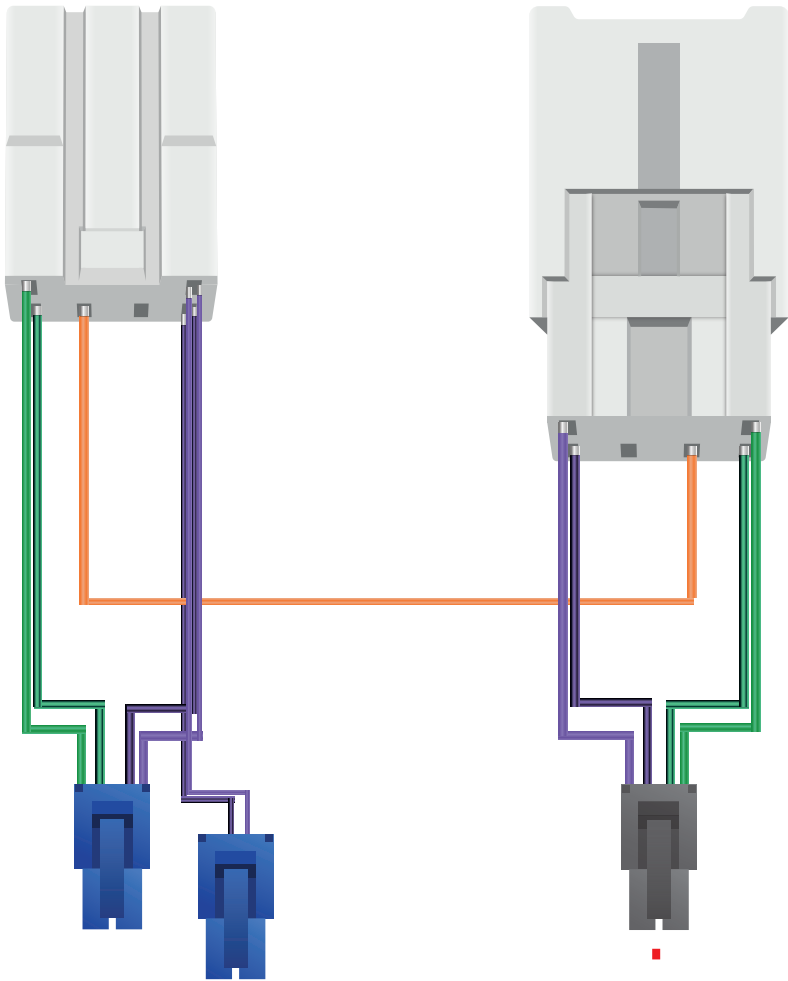

**DO NOT
CONNECT THE
BLACK MOLEX
PLUGS UNTIL
AFTER
COMPLETING
THE TUNING
PROCESS**

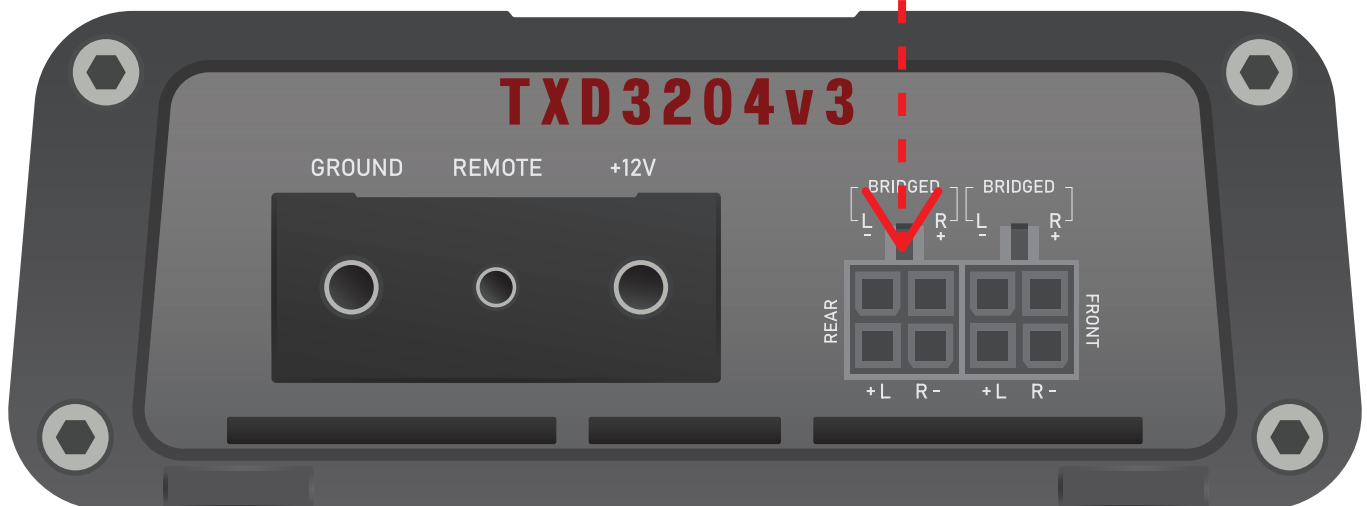

Harness 2

Black Molex Plug Connections

**DO NOT
CONNECT THE
BLACK MOLEX
PLUGS UNTIL
AFTER
COMPLETING
THE TUNING
PROCESS**

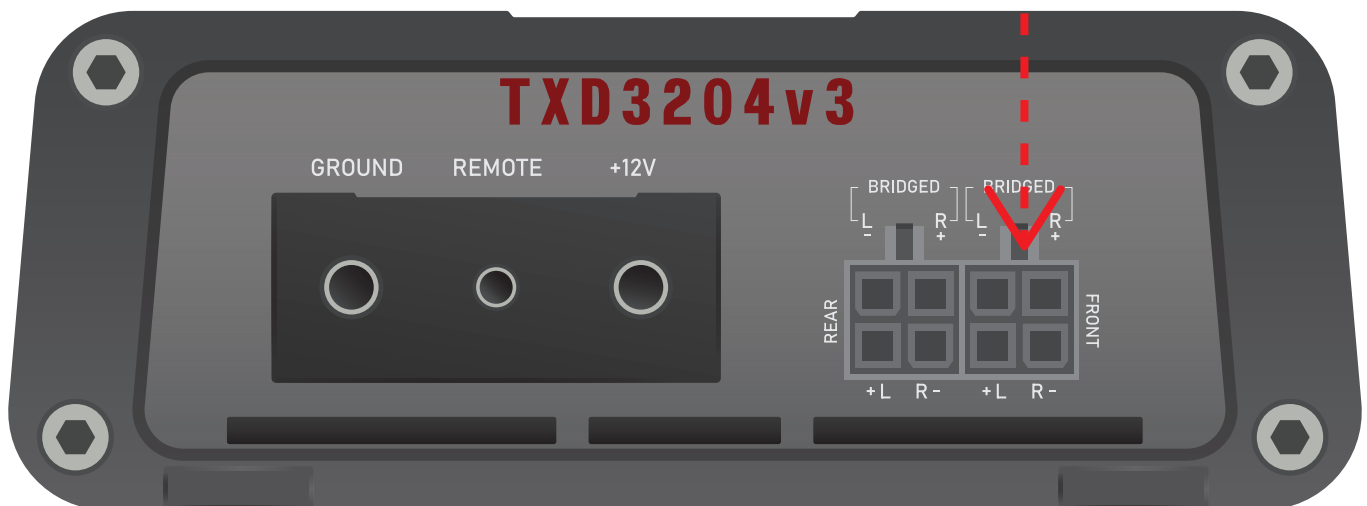
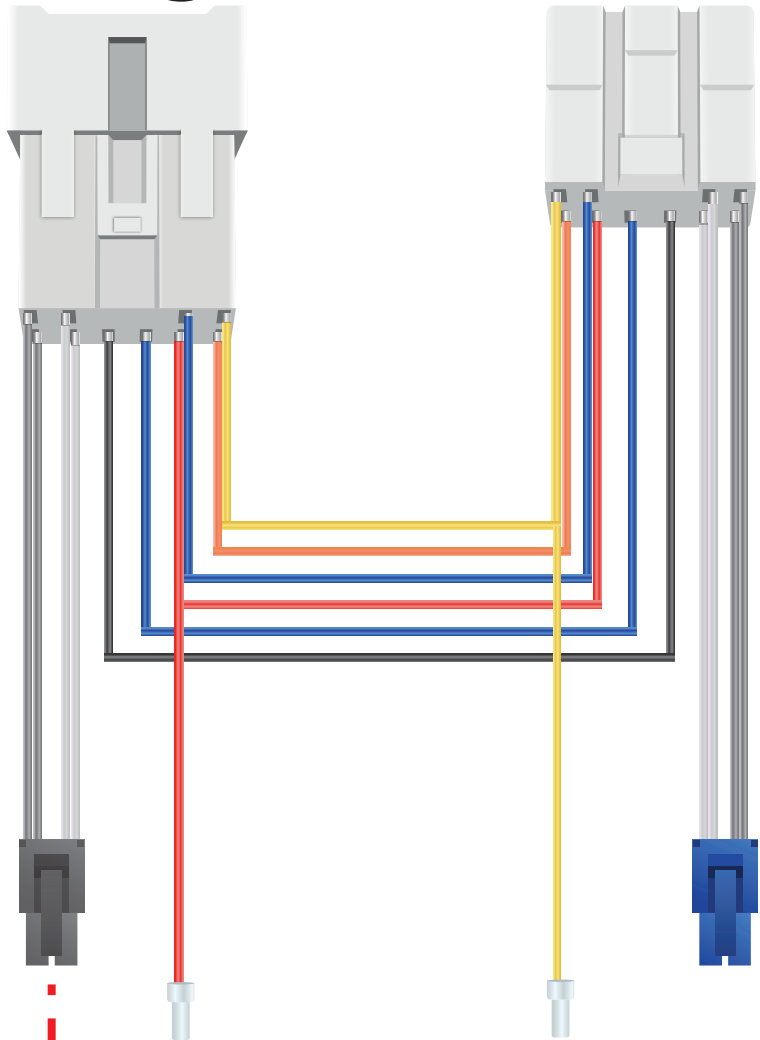

CONNECTIONS OVERVIEW

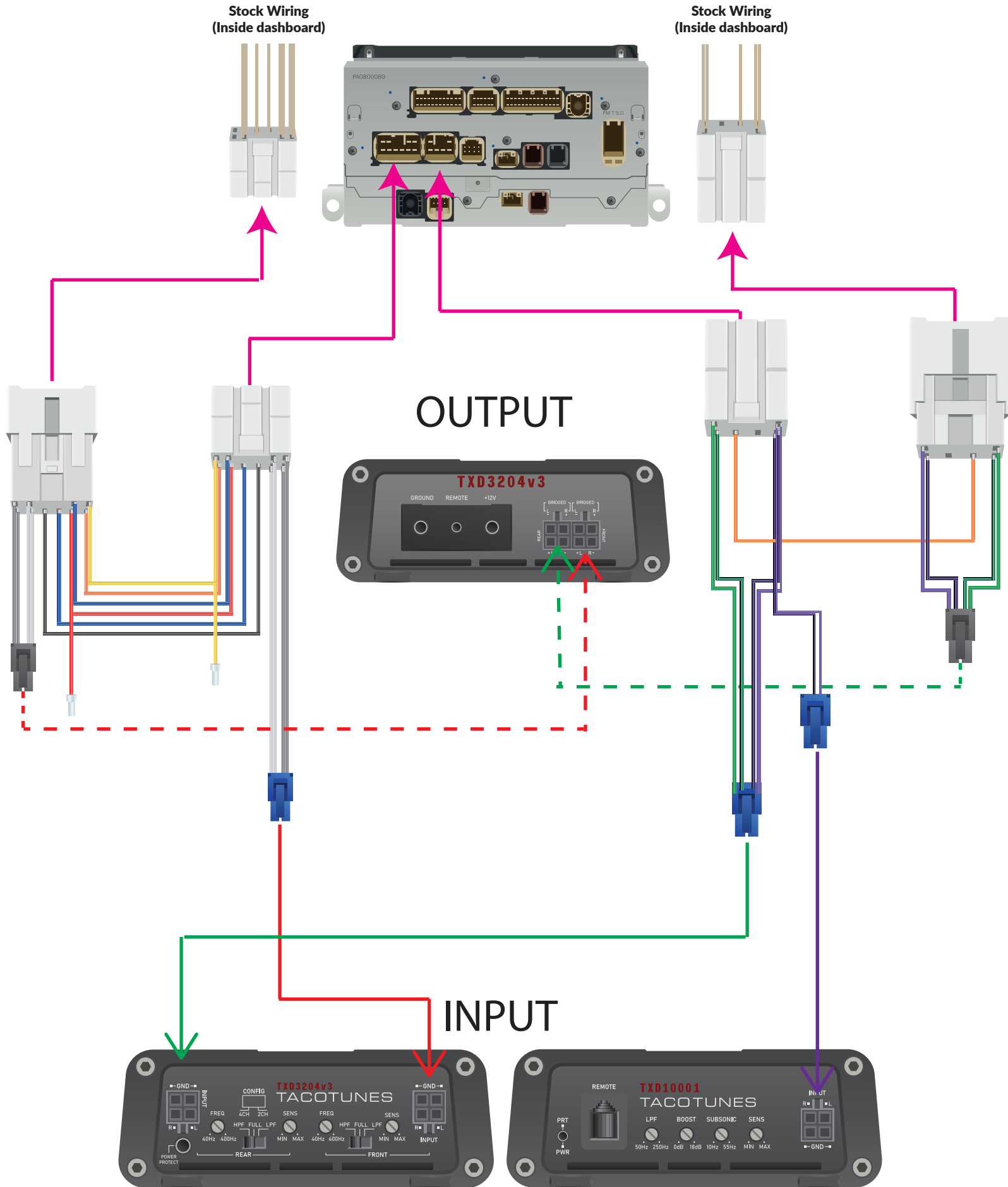

AMPLIFIER OUTPUT CONNECTION OVERVIEW

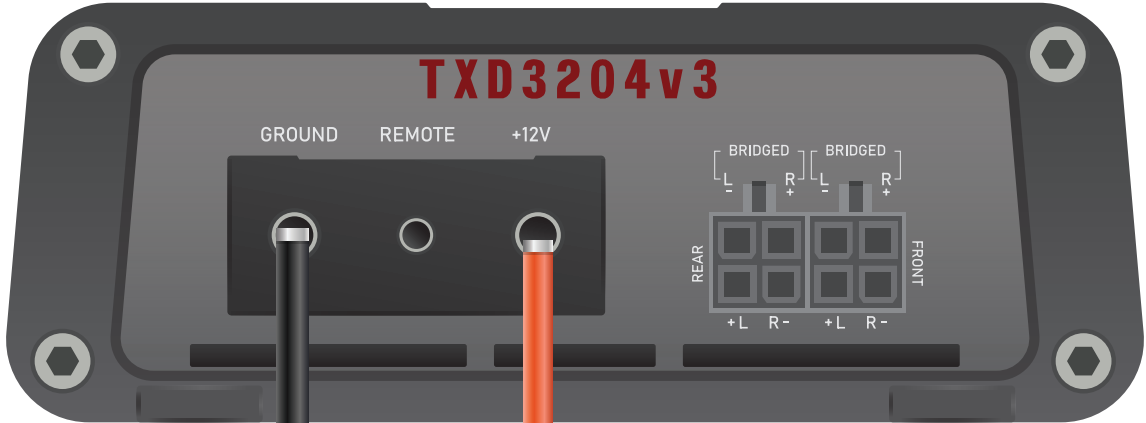

AMPLIFIER
GROUND,
GROUNDED TO
FACTORY
LOCATION

GROUND

POWER



AMPLIFIER
GROUND,
GROUNDED TO
FACTORY
LOCATION

12G Subwoofer wire connects to
subwoofer enclosure terminal cup

**DO NOT CONNECT SUB WIRING
TO TERMINAL CUP UNTIL AFTER
THE TUNING PROCESS IS
COMPLETED**

AMP RACK ASSEMBLY OVERVIEW

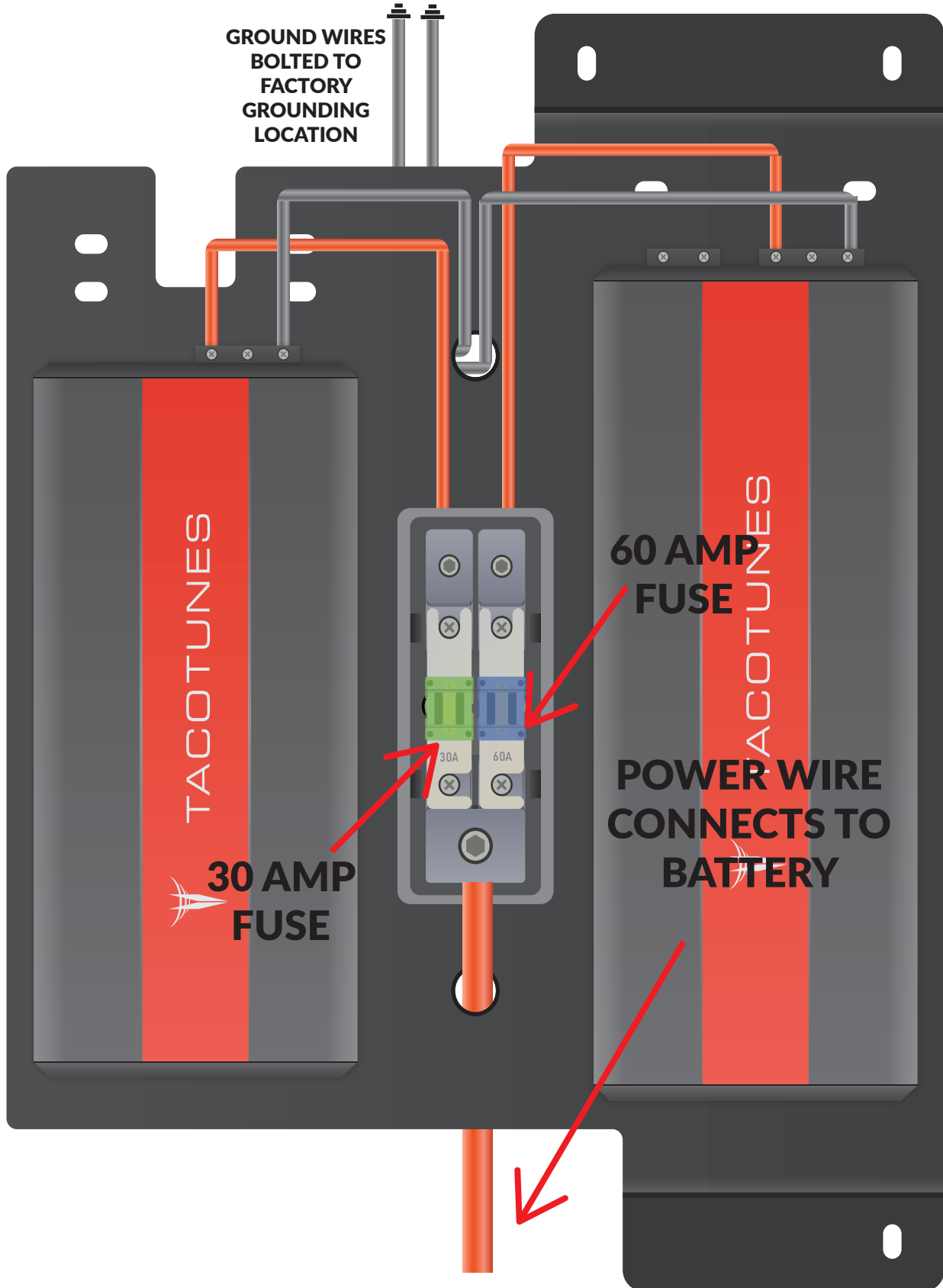

SUBWOOFER WIRING

Single Subwoofer Wiring

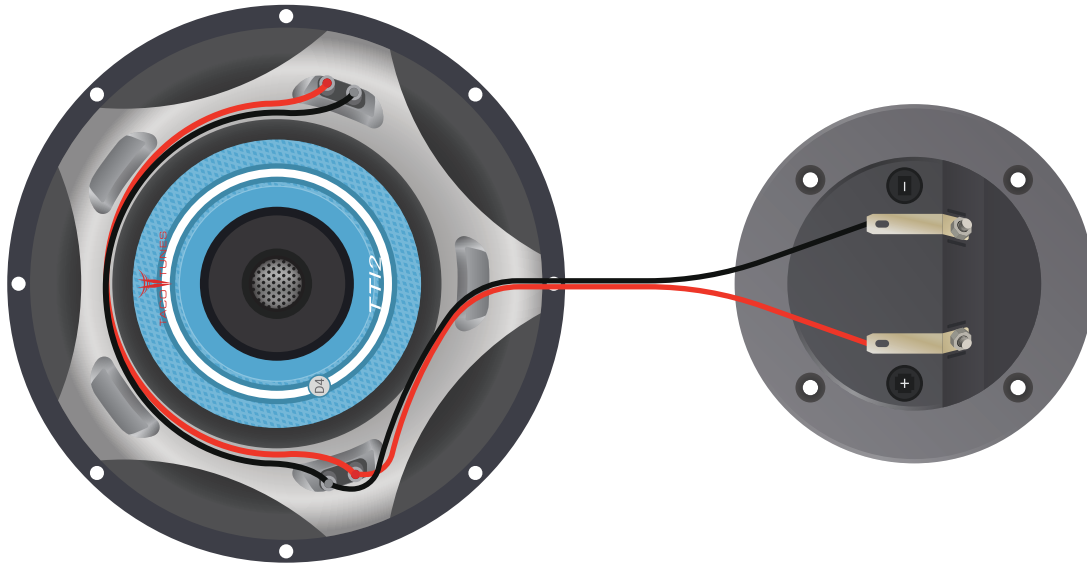

Dual Subwoofer Wiring

