

**2014-2021  
JBL EQUIPPED**

# **Toyota Tundra Audio Upgrade Plug & Play Harness Installation Manual**

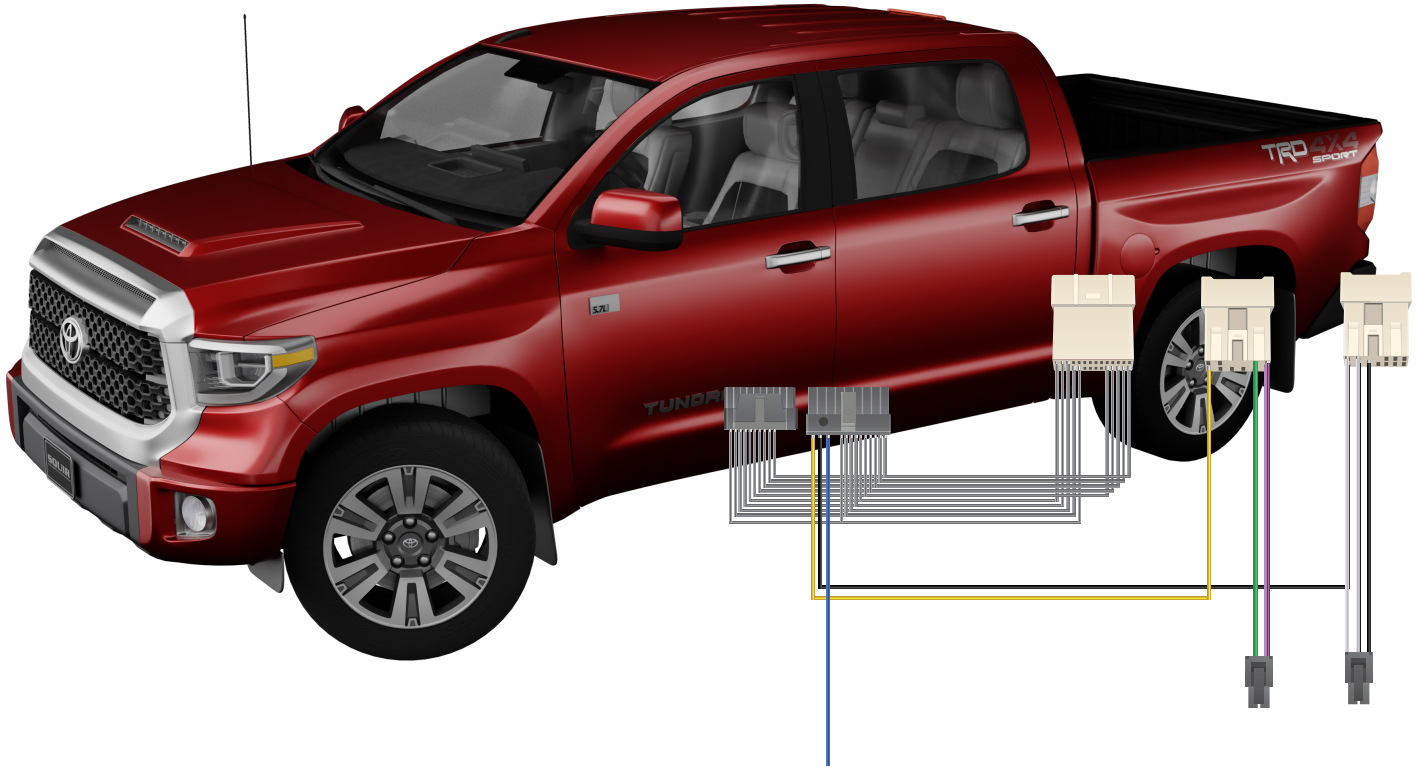

**Add 4 channel & Subwoofer Amplifiers  
to factory stereo**

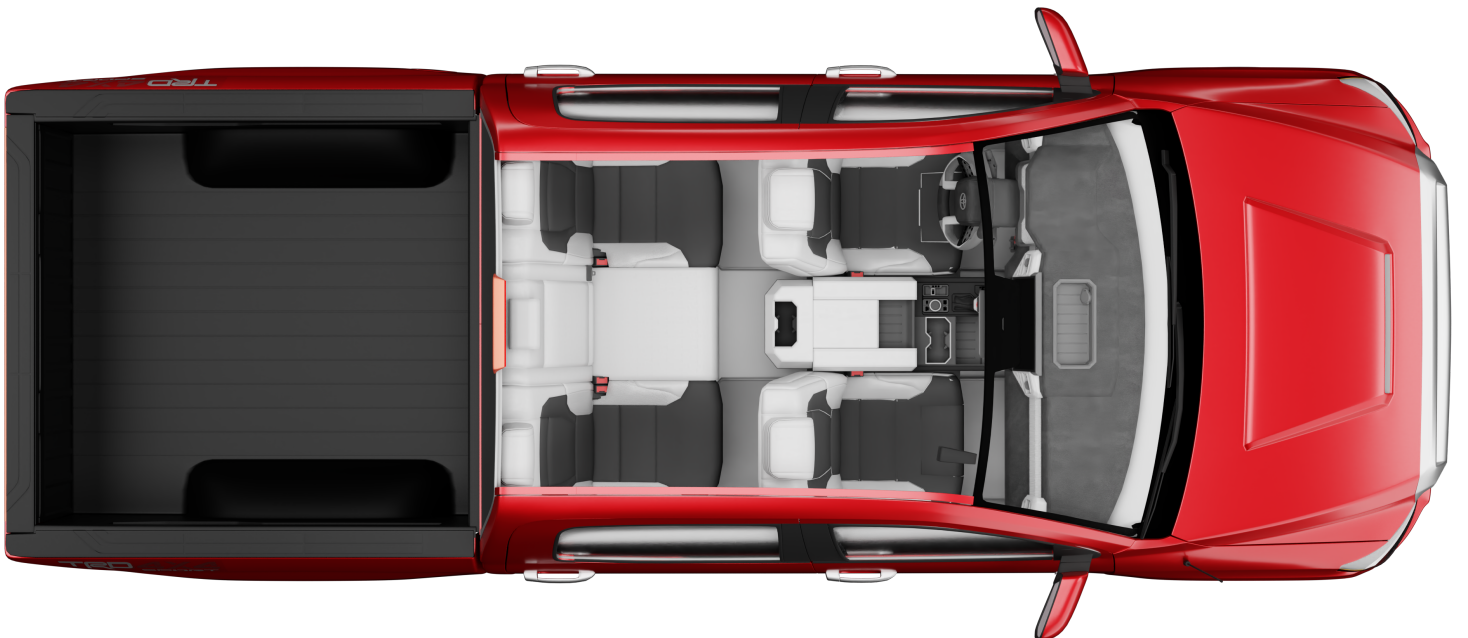

# PLUG & PLAY INTEGRATION OVERVIEW

**4G Power Wire**  
runs from  
battery to TXD  
Amplifiers

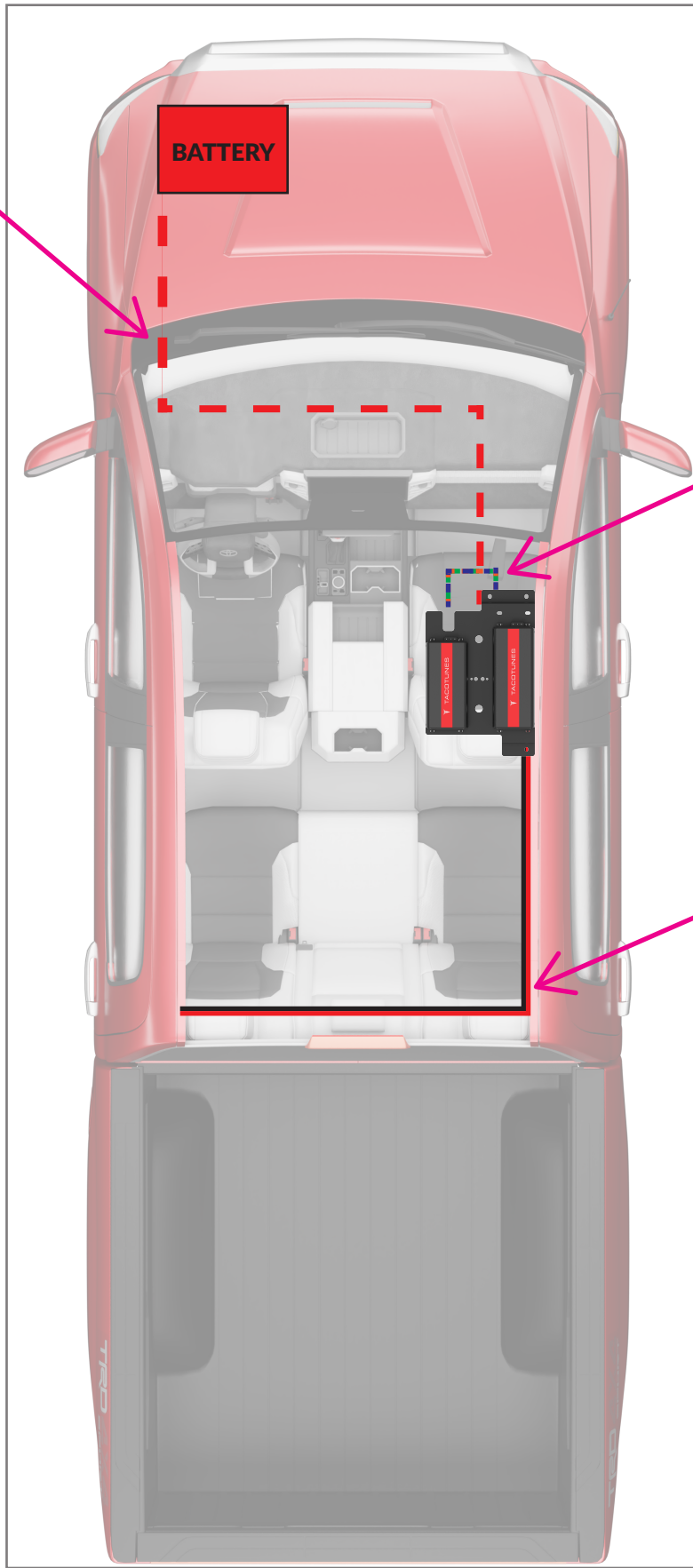

**Connect to factory**  
wiring under seat, &  
to Amplifiers:

**Plug & play harness**  
Integration Module

**12 Gauge**  
subwoofer wire  
ran from  
Subwoofer  
output to behind  
rear seat

## SECTION 1 -

# Plug and Play Harness Integration

## Factory Amp Under Seat

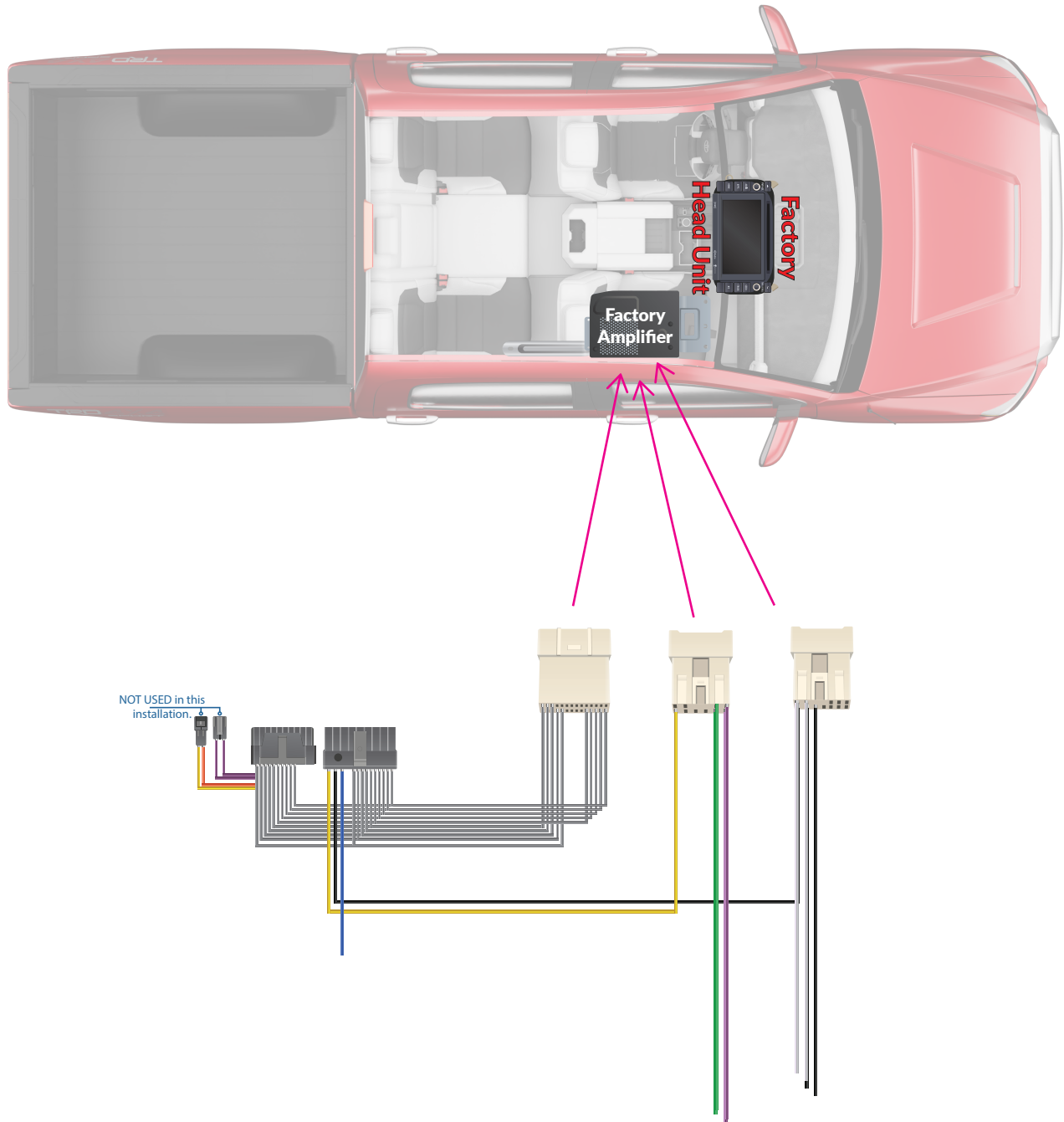

**Harness plugs directly into your factory wiring under the passenger seat.**

**Install these harnesses according steps on the following pages**

# REMOVE BLACK MOLEX PLUGS

NOT USED in this installation.

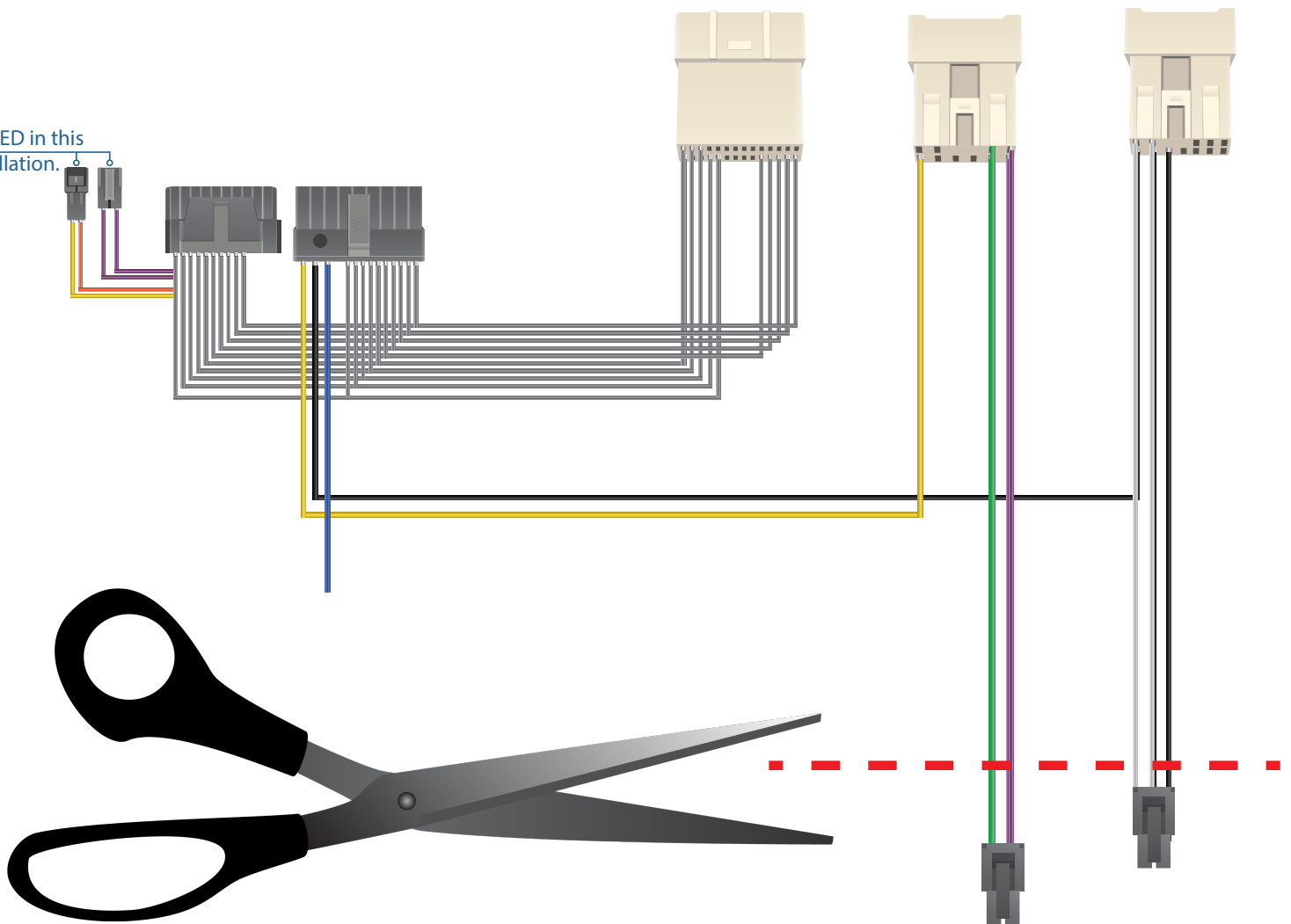

# Connect Harness to factory wiring



Factory Wiring

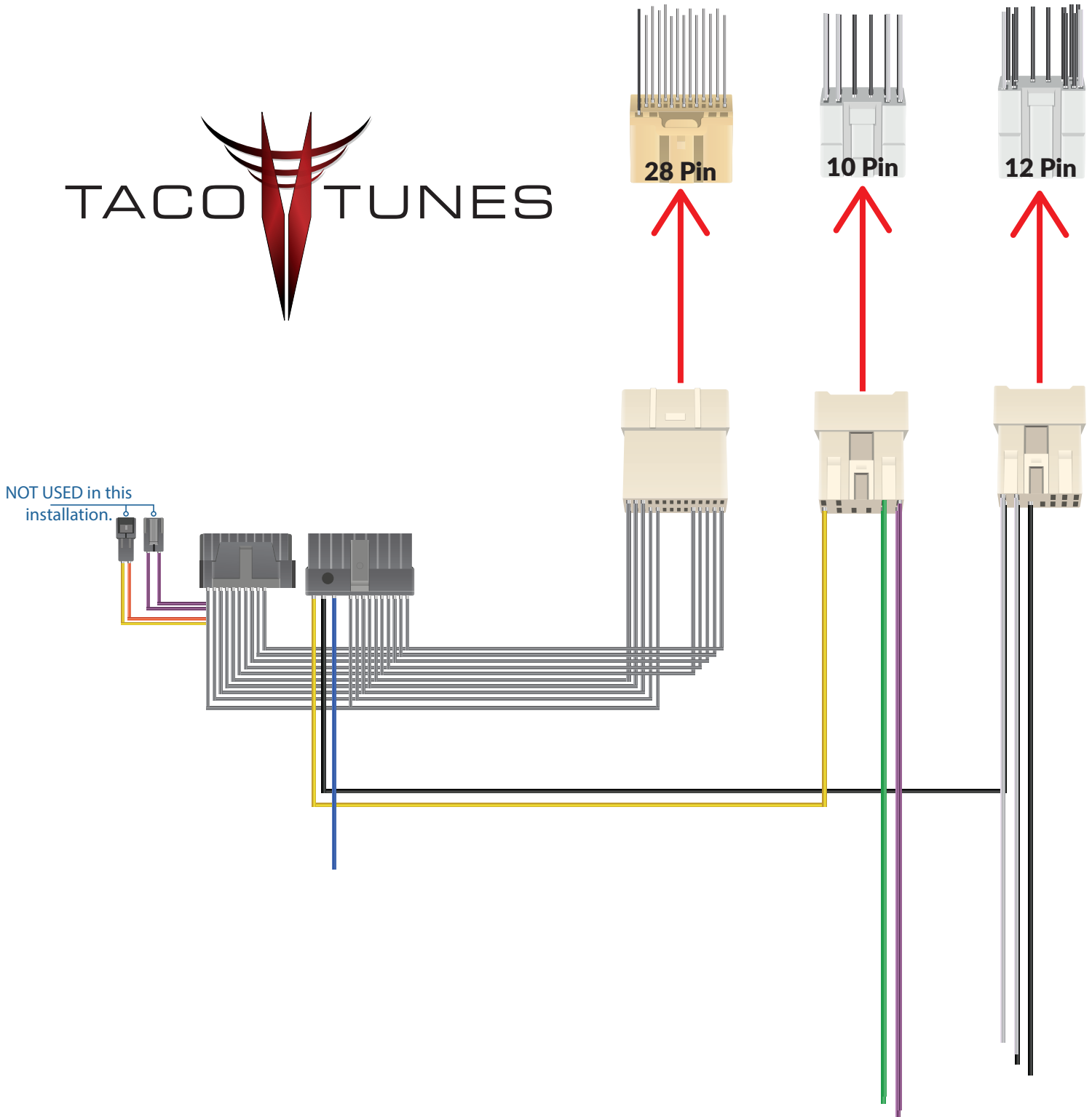

# Connect Harness to DSR1

NOT USED

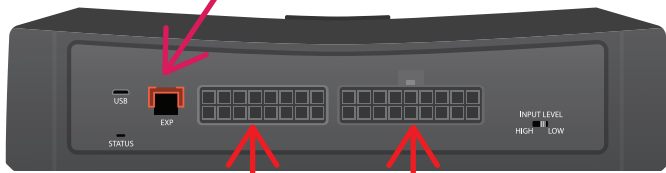

Connected to factory Wiring



28 Pin

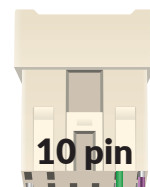

10 pin

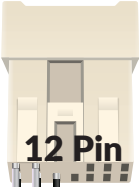

12 Pin

NOT USED  
in this  
installation.

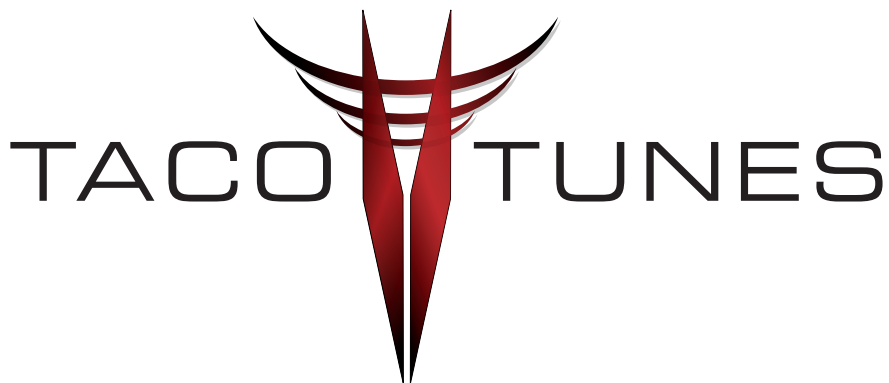
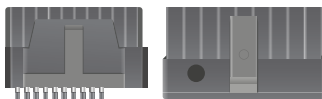

# Connect RCA Cables to DSR1

NOT USED



**DSR1 has been flashed.  
DO NOT FLASH AGAIN!**

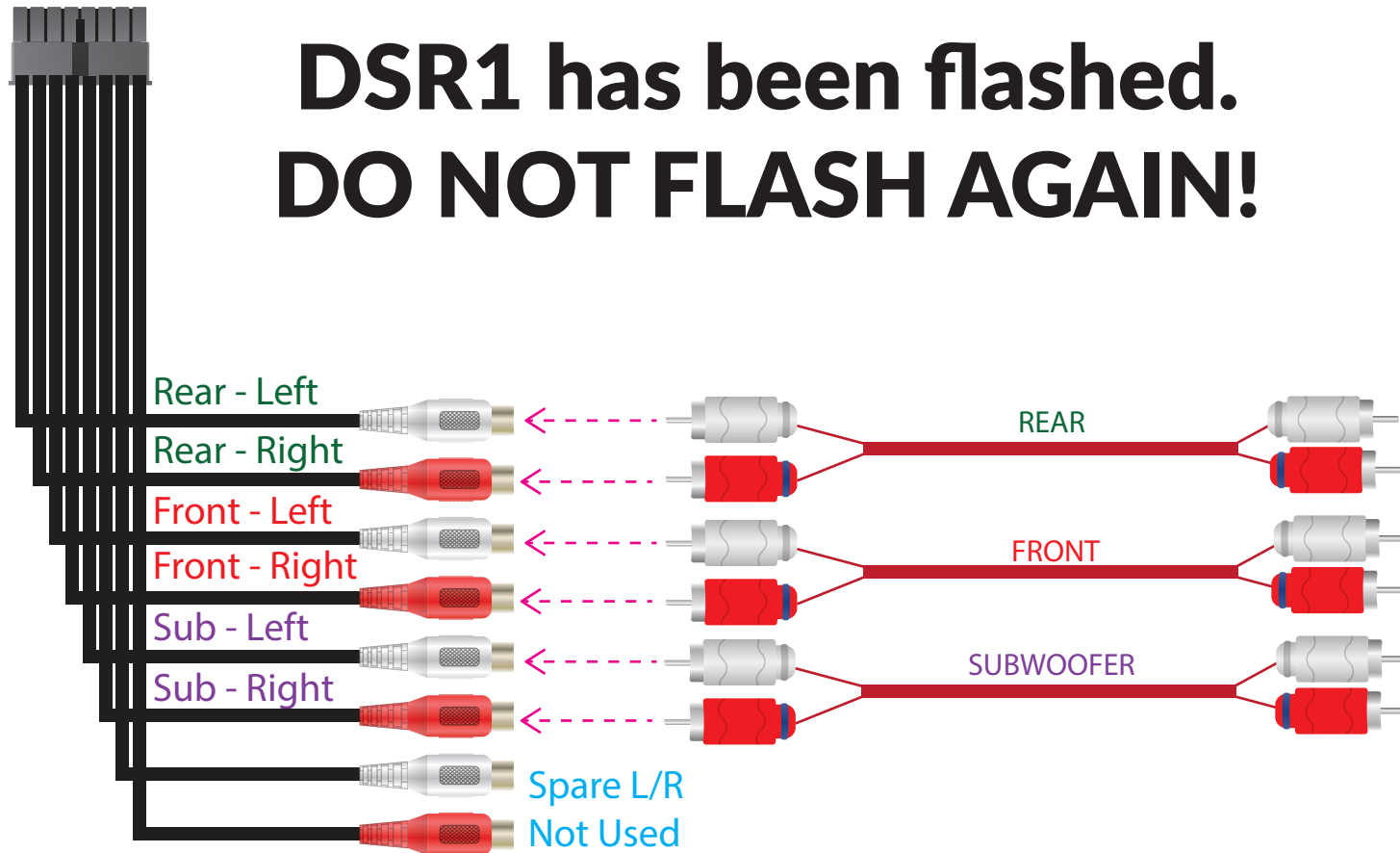

# Connect RCA Cables to Amplifiers

## RCA Cables connected to DSR1

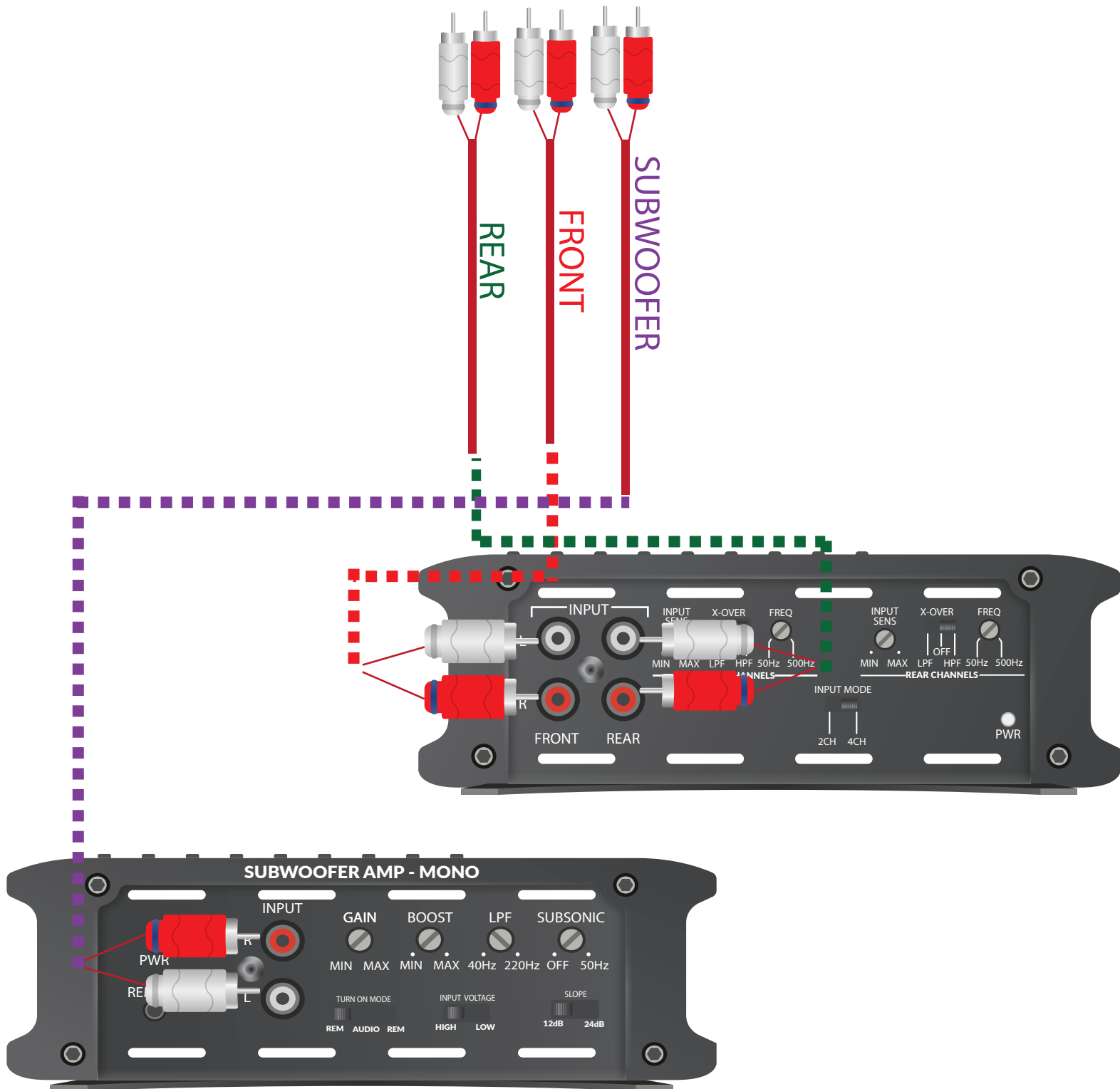



# Connect Harness Leads to output on Amplifiers

Connected to factory wiring

NOT USED

Connected to DSR1

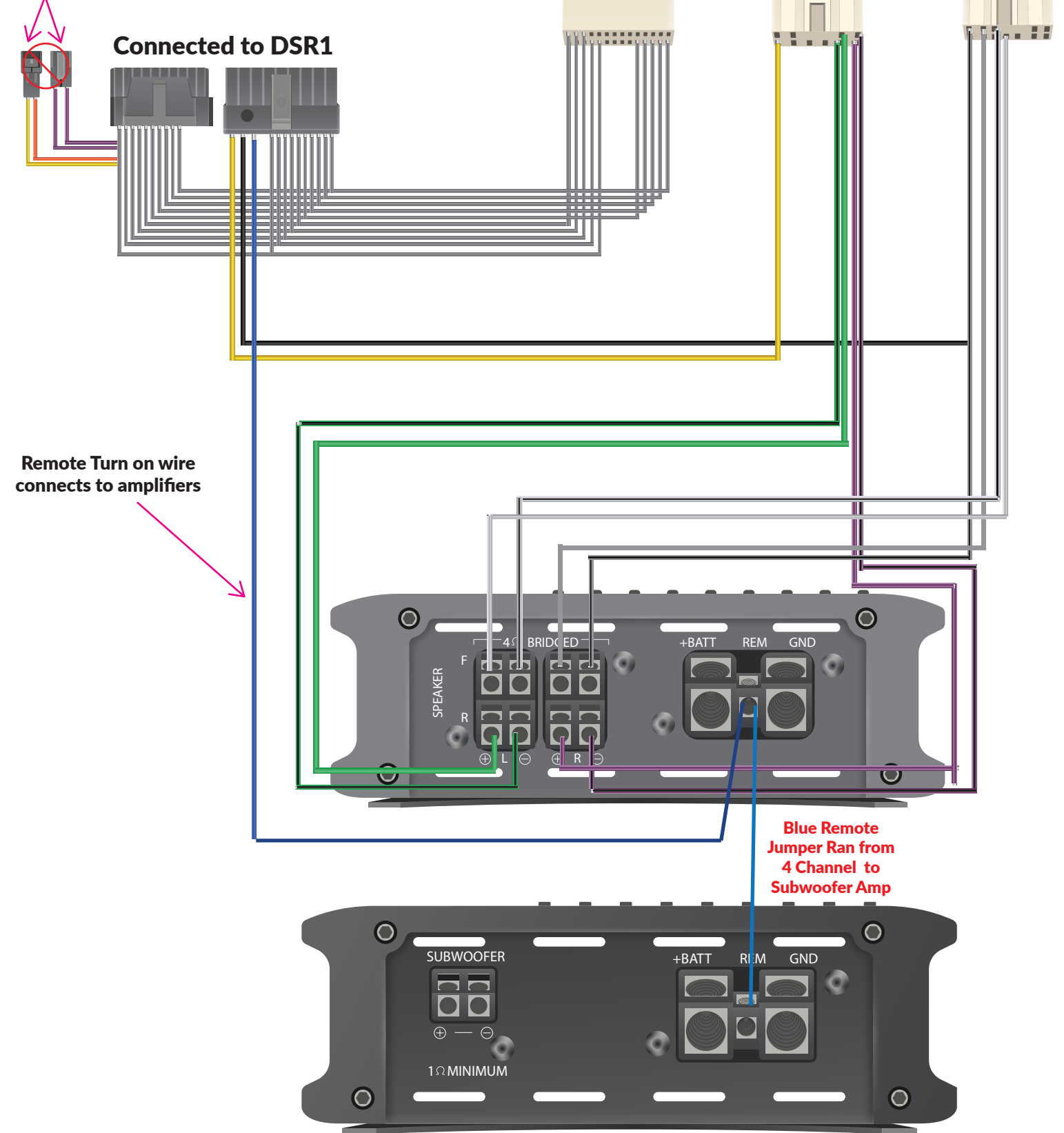

# CONNECTION OVERVIEW

