

2014-2021 Toyota Tundra Audio Upgrade

Complete Installation Manual



SYSTEM 1B

Aftermarket Head Unit Connections

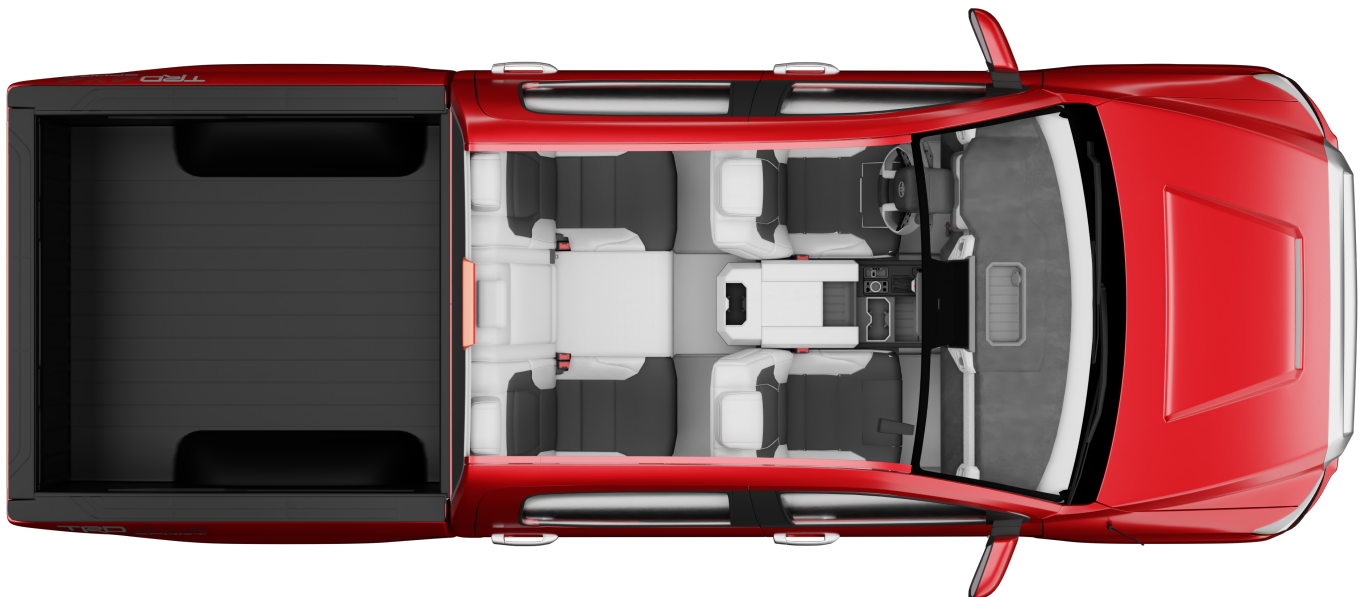

PLUG & PLAY INTEGRATION OVERVIEW

4G Power Wire
runs from
battery to TXD
Amplifiers

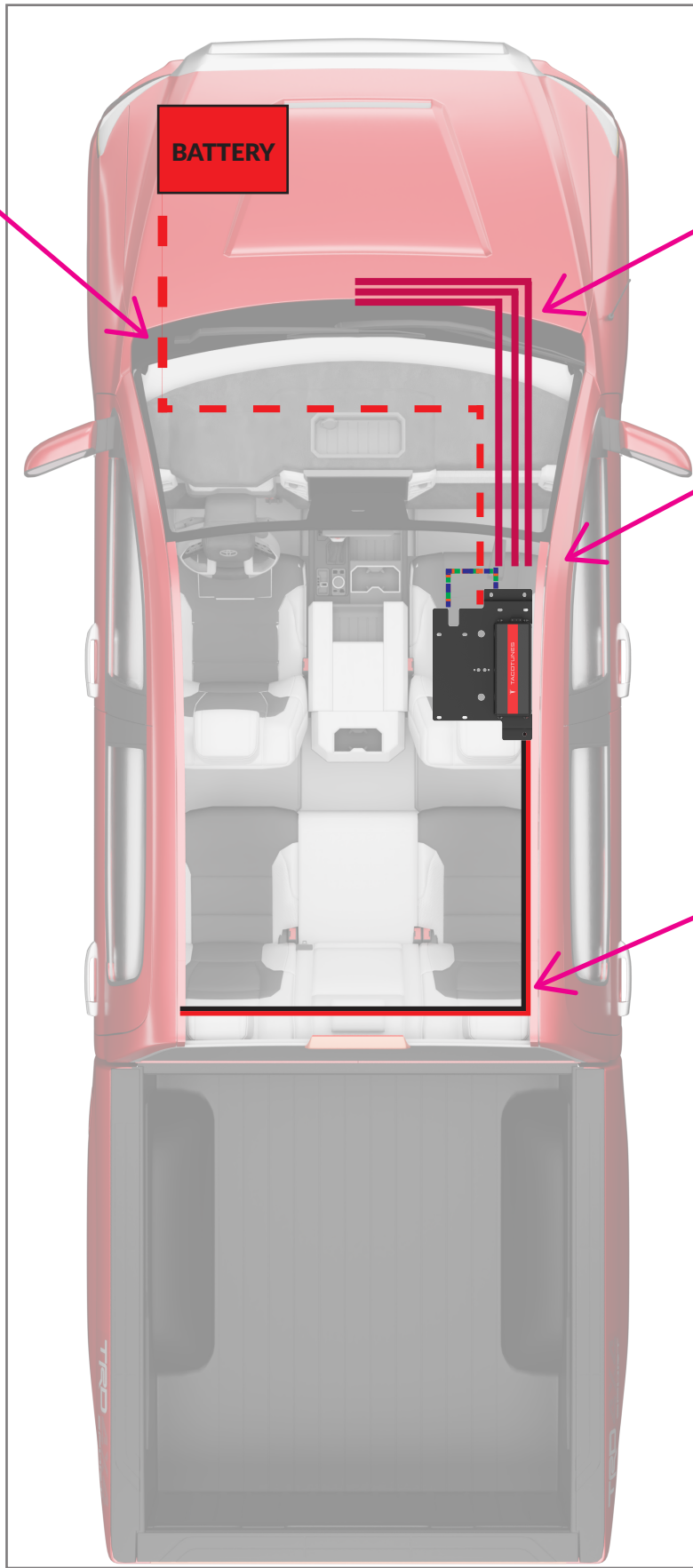

RCA Cables ran from
aftermarket head unit
to TXD Amplifiers

Connect to factory
wiring under seat, &
to TXD Amplifiers:

Plug & play harness 1
Plug & play harness 2

12 Gauge
subwoofer wire
ran from
TXD1000.1 to
behind rear seat

FAQ

Read below for headunit feature recommendations

The diagram below is to help our customers that want to add an aftermarket head unit to their tacotunes System 1A or System 1B audio system. Most of our customers want to keep their stock head unit and maintain a stock look. However, some customers that would like to add Apple Car Play / Android Auto to their system ask for advice on how to select a new head unit. New head units are very similar to selecting a new watch. They all tell “time” but some of them have some nice helpful features. We are going to limit our suggestions to help you obtain the best sound quality possible. As the “consumer” you will have to decide which head unit to select. In the future we may offer some head unit options, but due to the low demand (at this time), we are going to help you select the right head unit.

We suggest that your new head unit is equipped with the following functions:

- 1. Six channel RCA output Front/Rear/ Subwoofer outputs.**
- 2. Internal High and Low Pass Filters. (Crossovers)**
- 3. We suggest selecting a head unit that is compatible with Idatalink’s Maestro. The maestro makes it much easier to integrate your stock backup camera, steering wheel controls and a number of other factory functions.**
- 4. In most cases we replace the stock microphone with the microphone included with the new head unit.**
- 5. We don’t suggest purchasing a head unit with a GPS/Mapping option. Those features are better provided via your Apple or Android device. Plus, you will save a good amount of money for a feature that you really don’t need.**

NOTE: We will continue to update these suggestions.

SECTION 1 -

Plug and Play Harness Integration

Factory Amp Under Seat

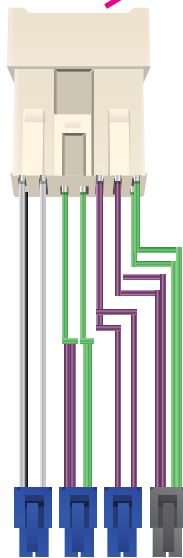
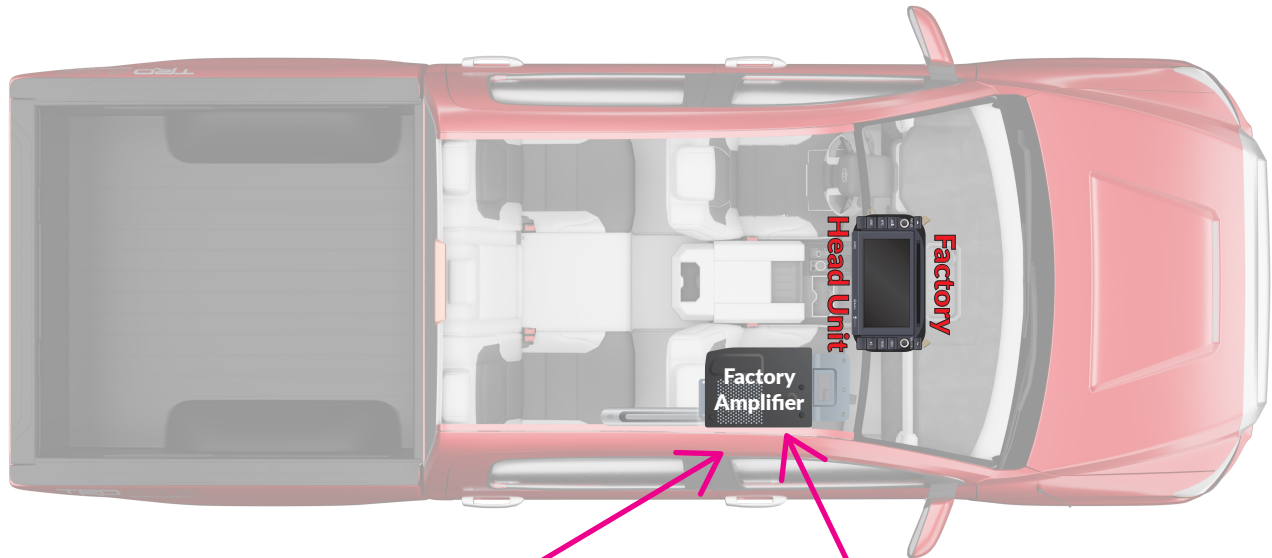

Harness 1

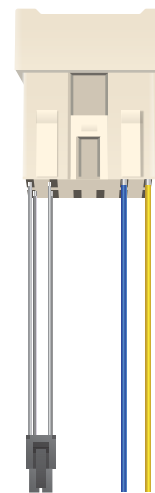

Harness 2

Harness 1 & 2 plug directly into your factory wiring under the passenger seat.

Install these harnesses according steps on the following pages

SECTION 1a -

REMOVE FACTORY AMP

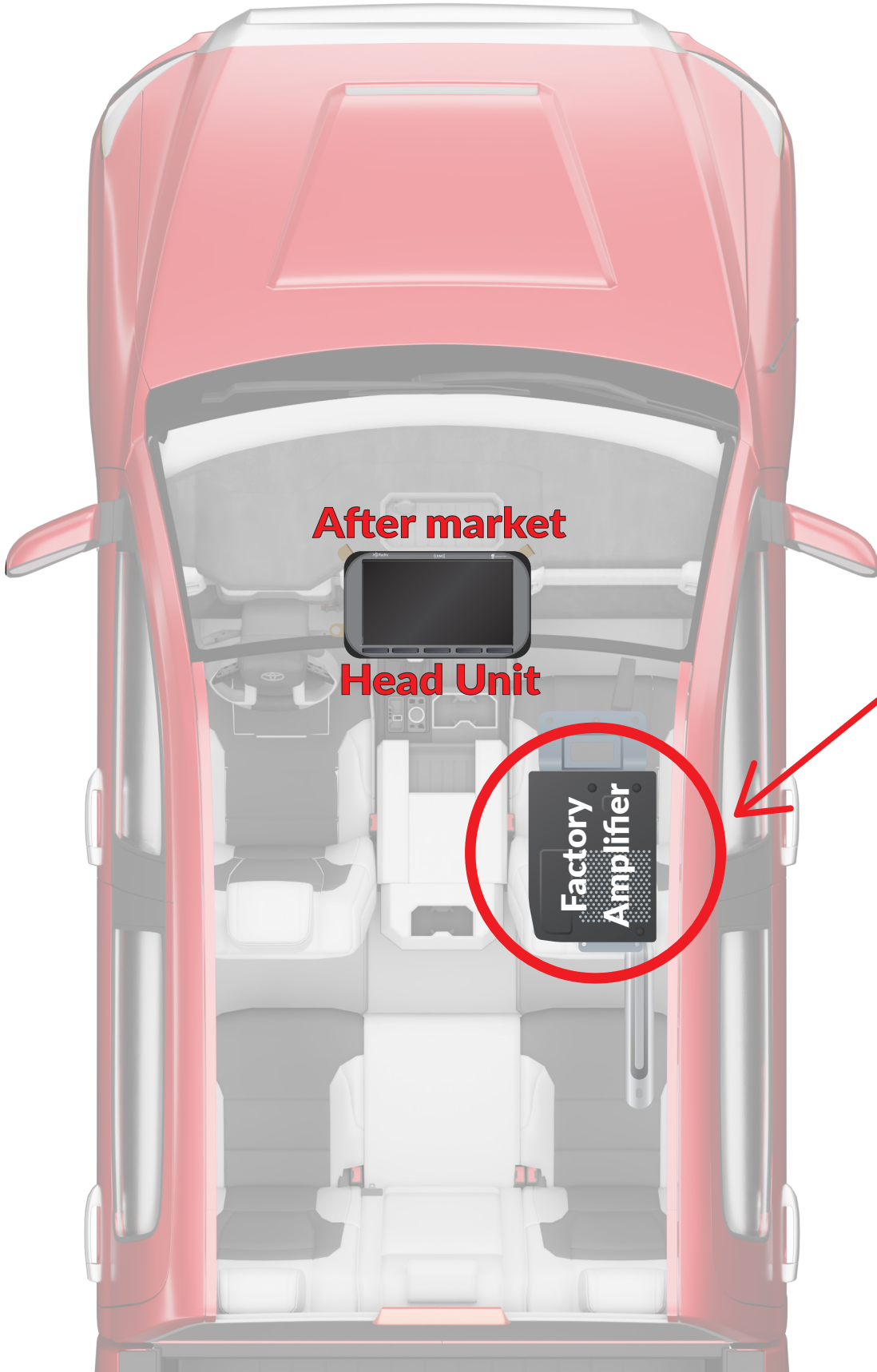

After market



Head Unit



**Remove
Factory
Amplifier**

SECTION 1b -

CONNECT PLUG & PLAY WIRING

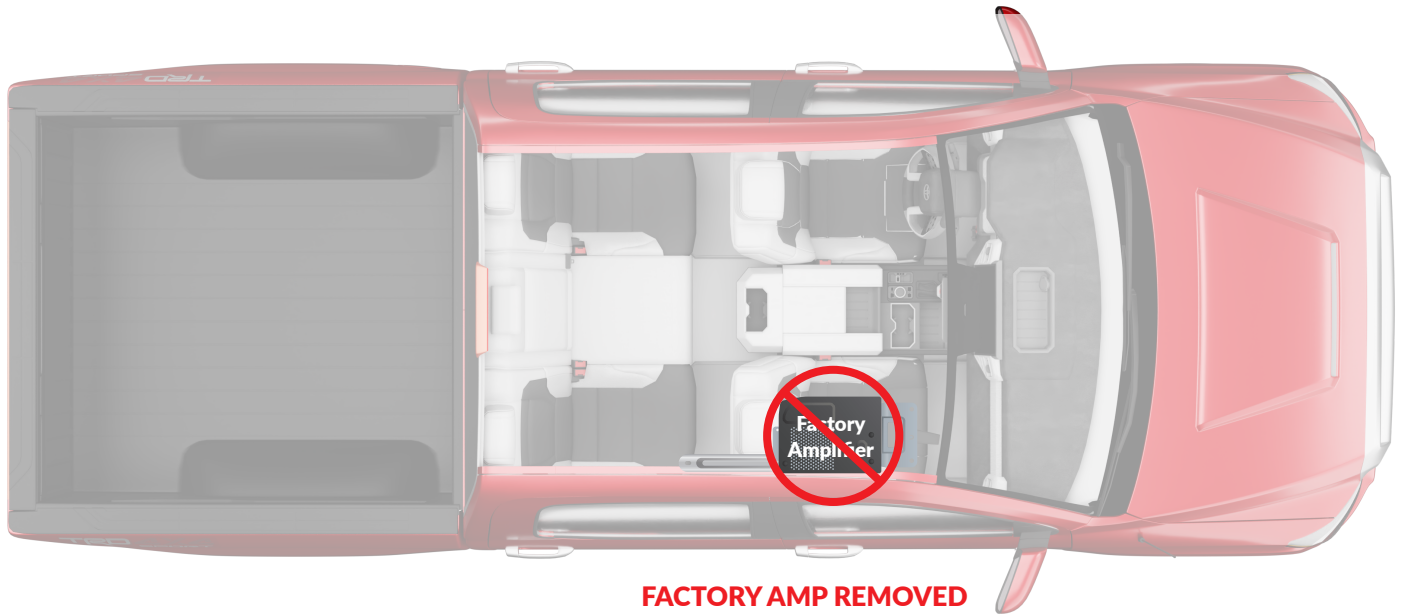

FACTORY AMP REMOVED

CONNECT PLUG AND PLAY HARNESS 1 & 2 TO FACTORY WIRING UNDER SEAT

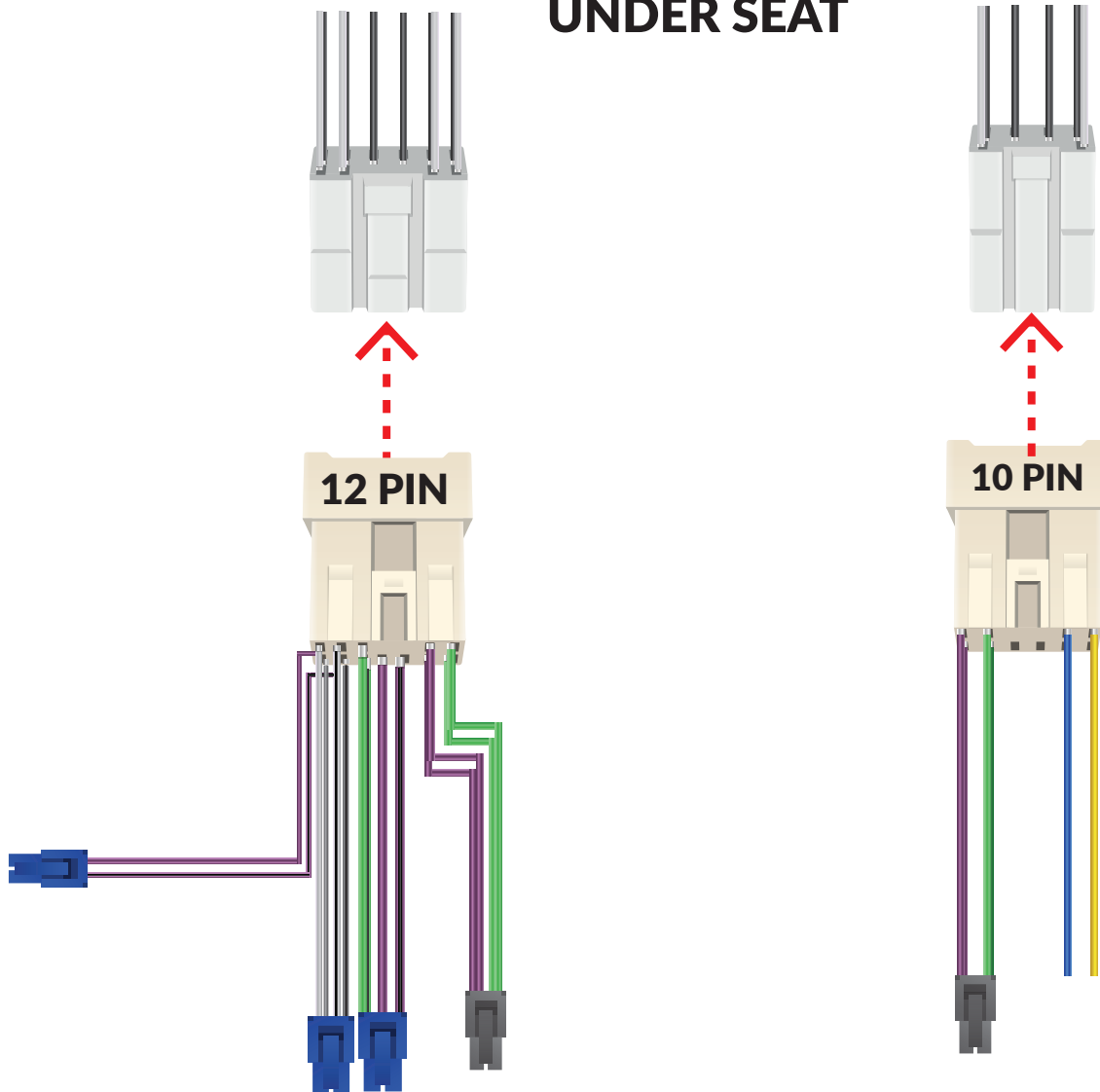

Connect RCA Cables to Amplifiers

RCA Cables connected to Aftermarket Head Unit

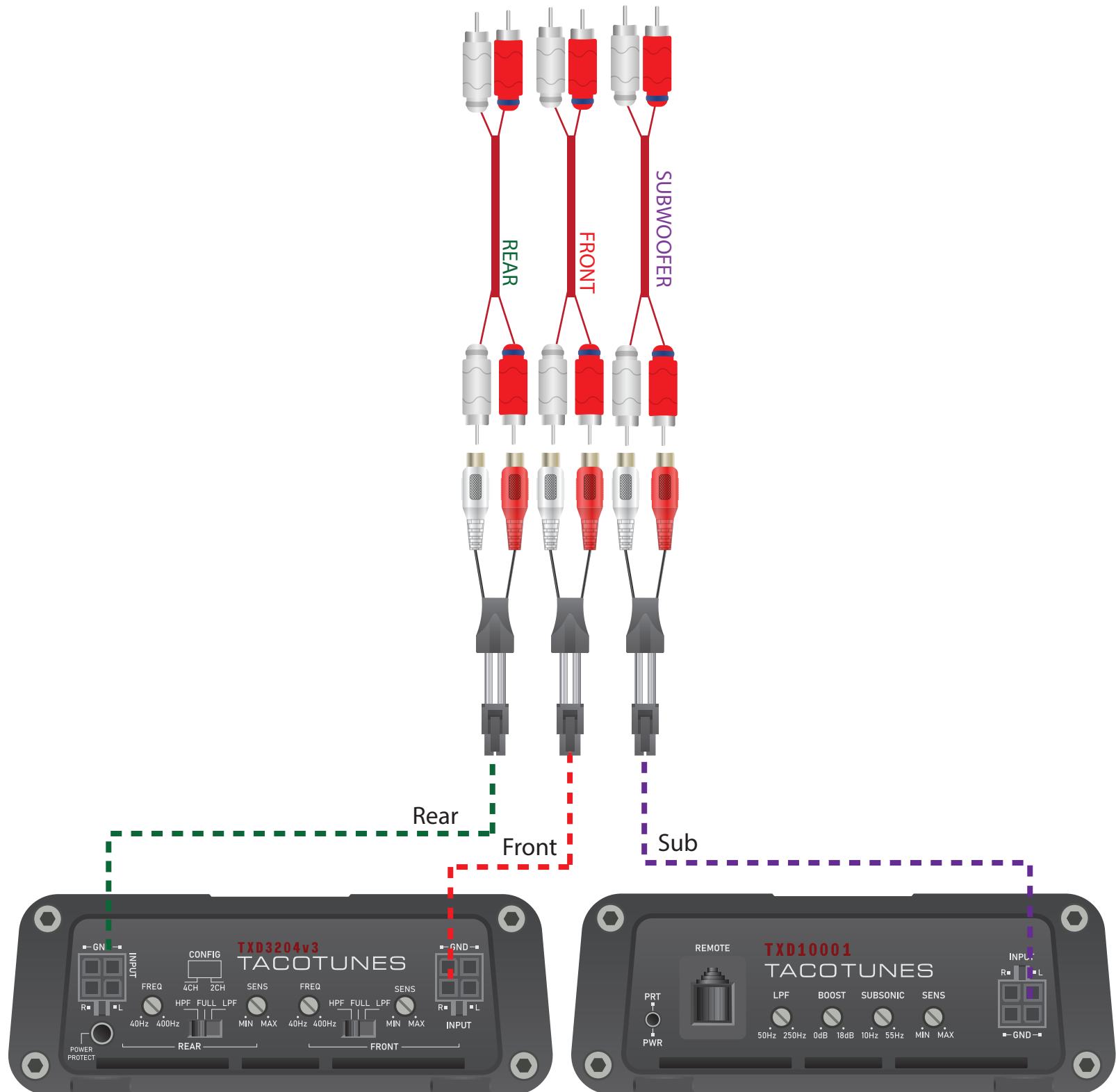

BLACK MOLEX PLUGS

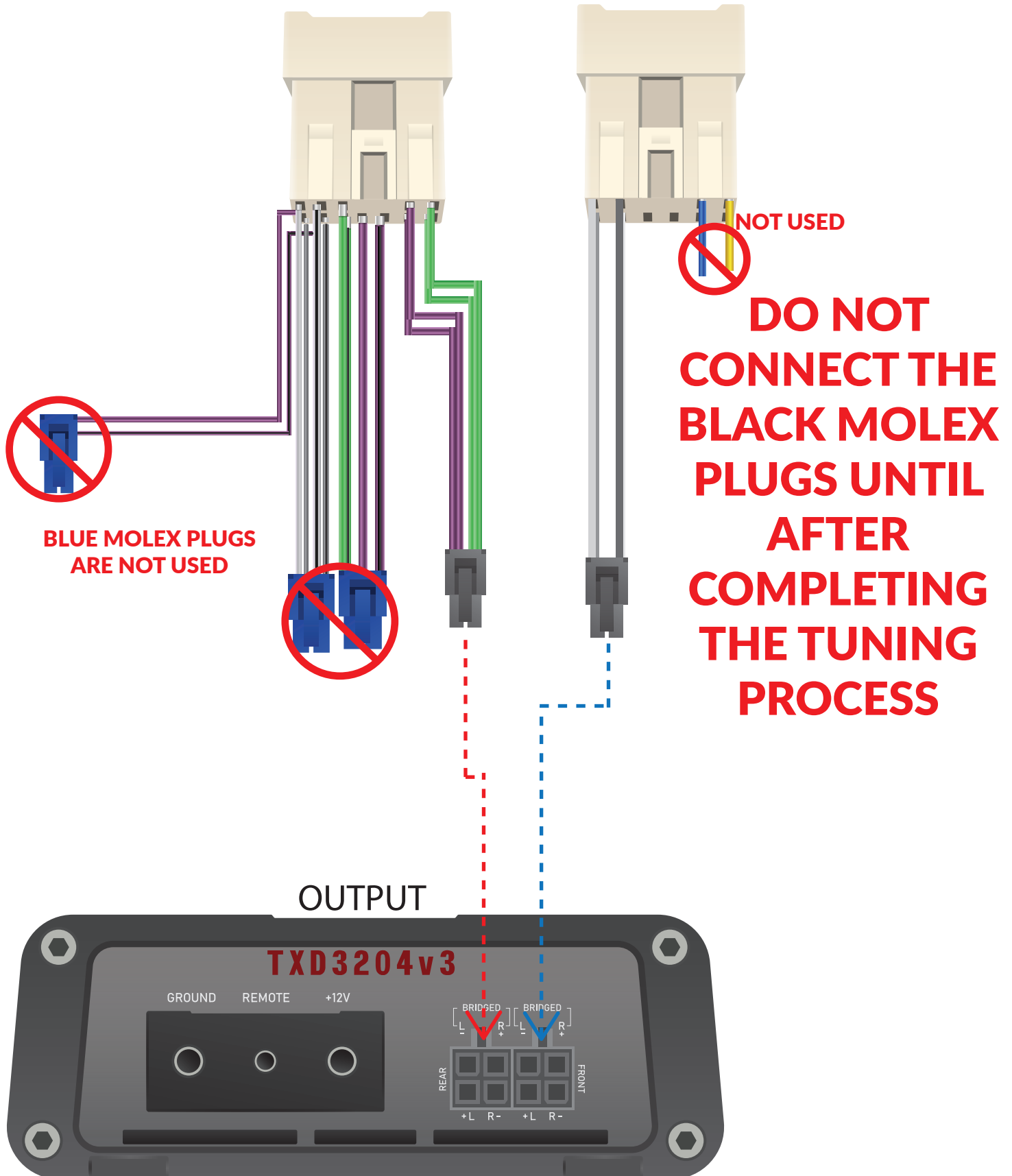

BLUE REMOTE TURN ON WIRE

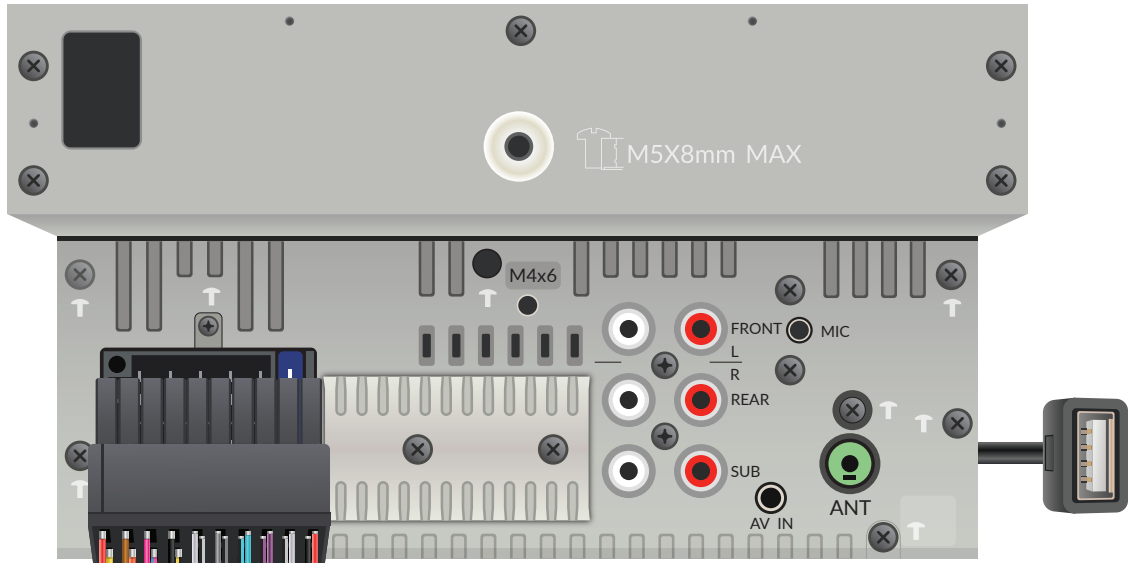

Connect blue remote turn on wire to your head unit

Refer to your head unit's manual for the correct connection

Connect blue remote wire to REMOTE connection on amplifier



Blue jumper wire from TXD3204 to TXD1000.1

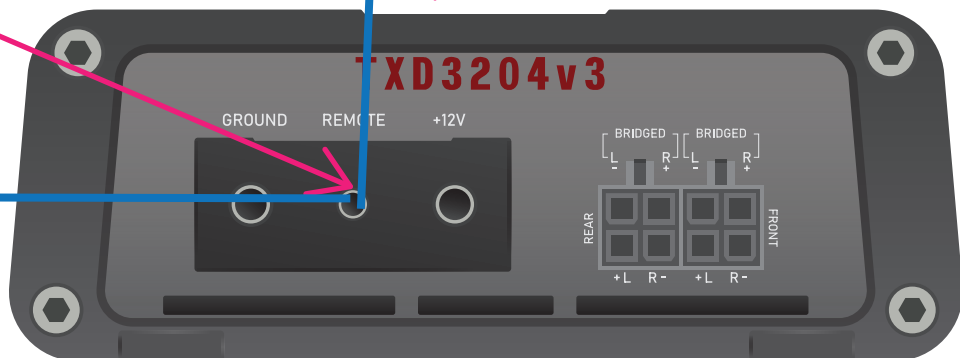

PLUG AND PLAY HARNESS CONNECTION OVERVIEW

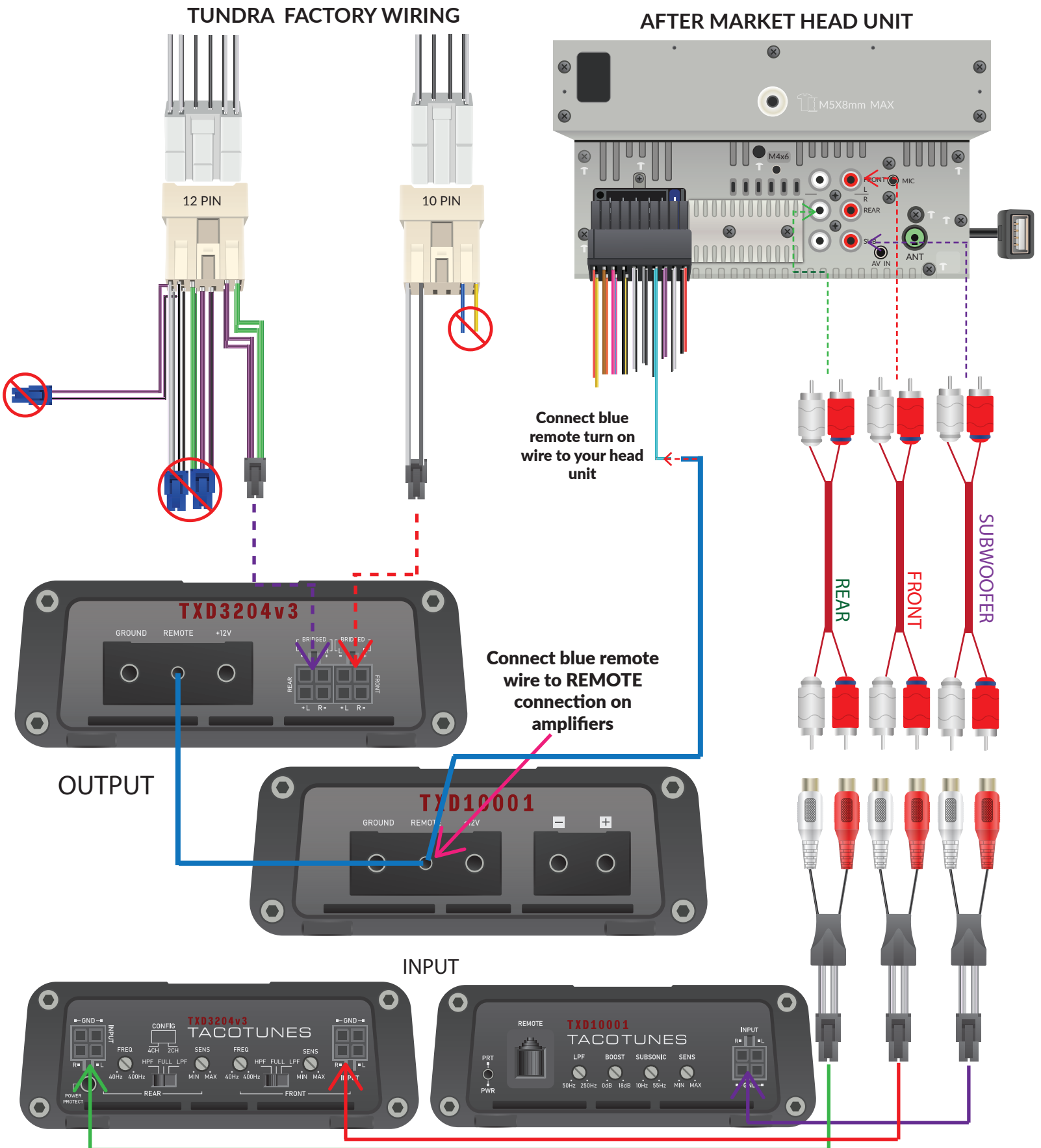

Amp Rack Assembly

Amp Grounded to
factory location

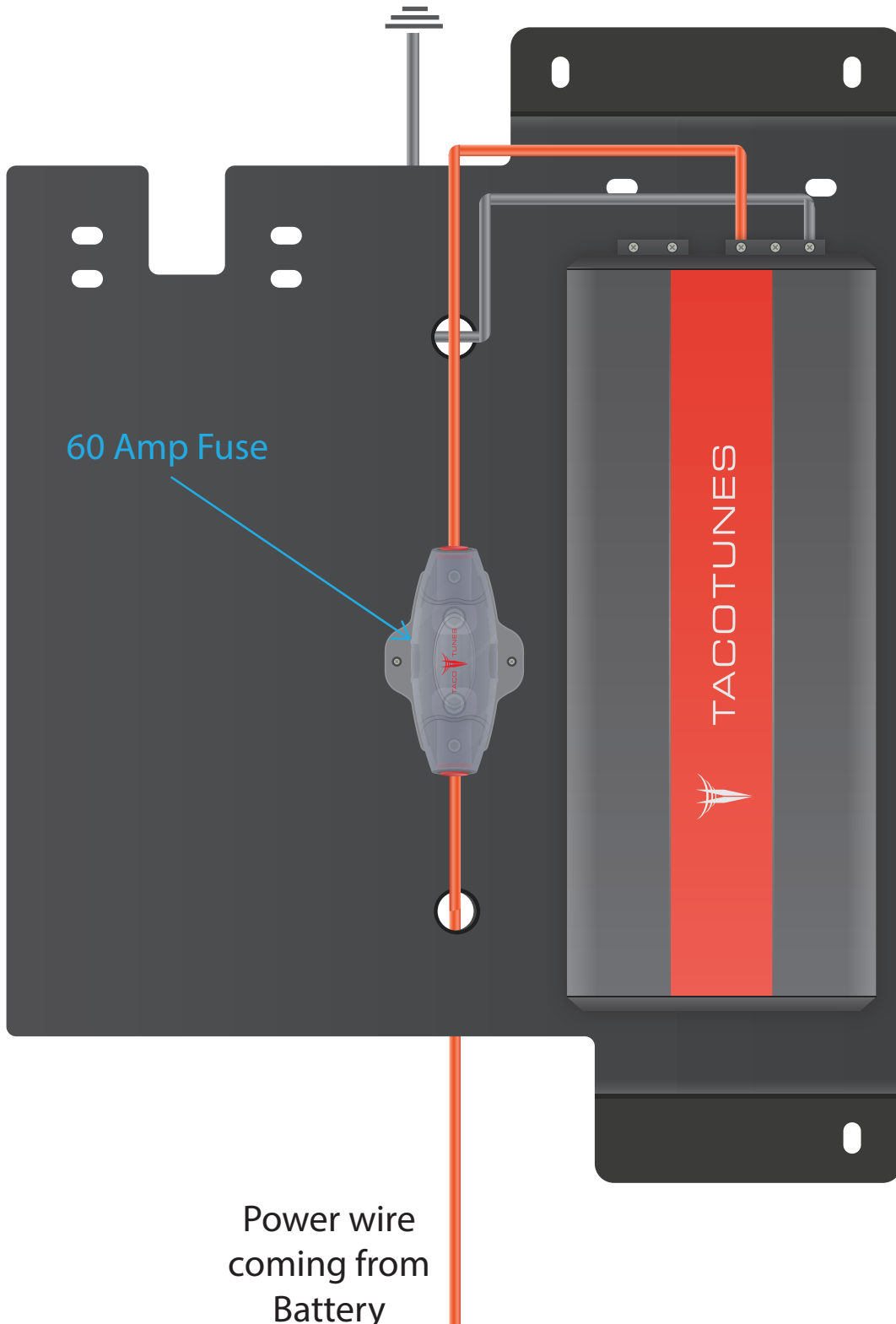

AMPLIFIER OUTPUT CONNECTION OVERVIEW

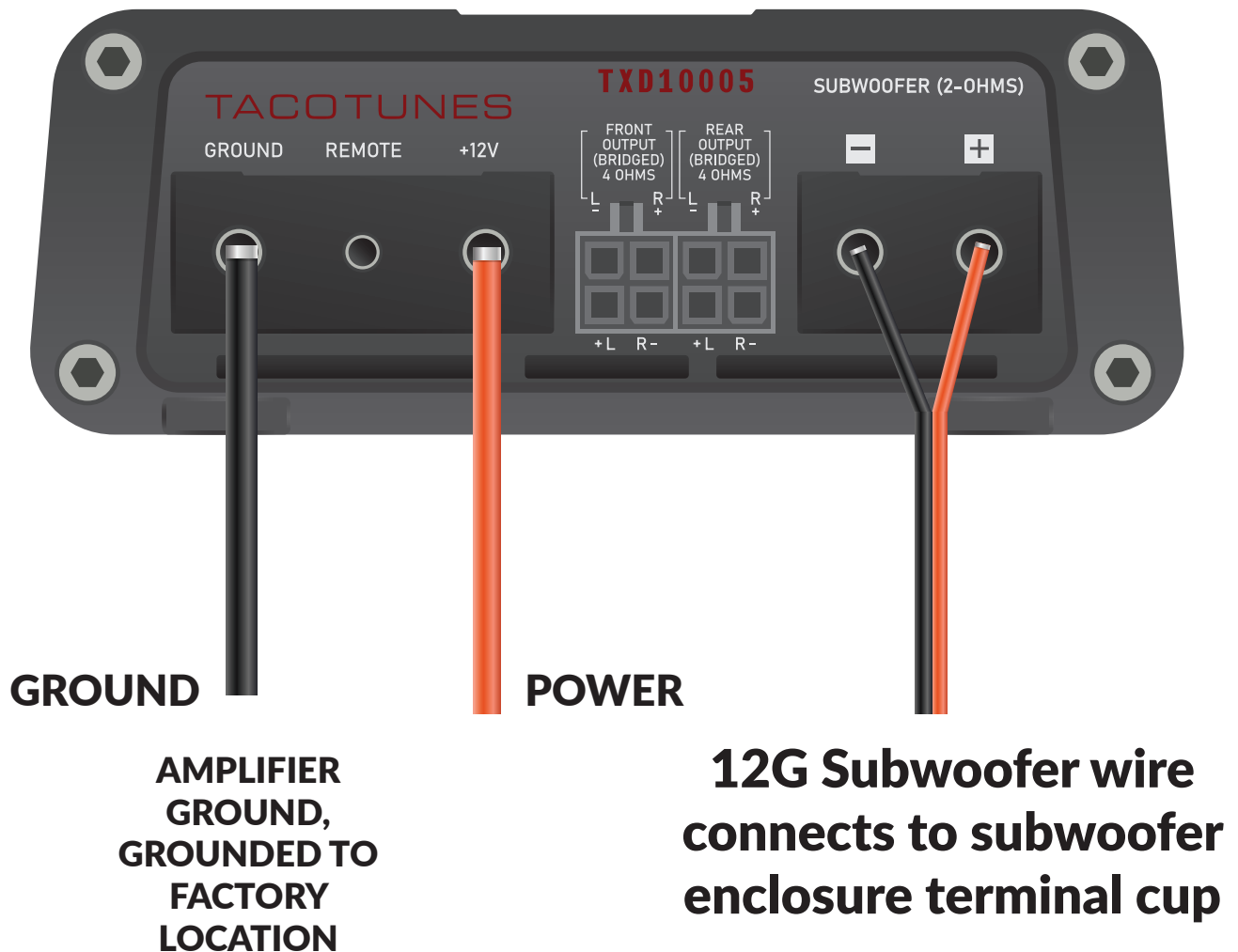

DO NOT CONNECT SUB WIRING TO TERMINAL CUP UNTIL AFTER THE TUNING PROCESS IS COMPLETED

SUBWOOFER WIRING

Single Subwoofer Wiring

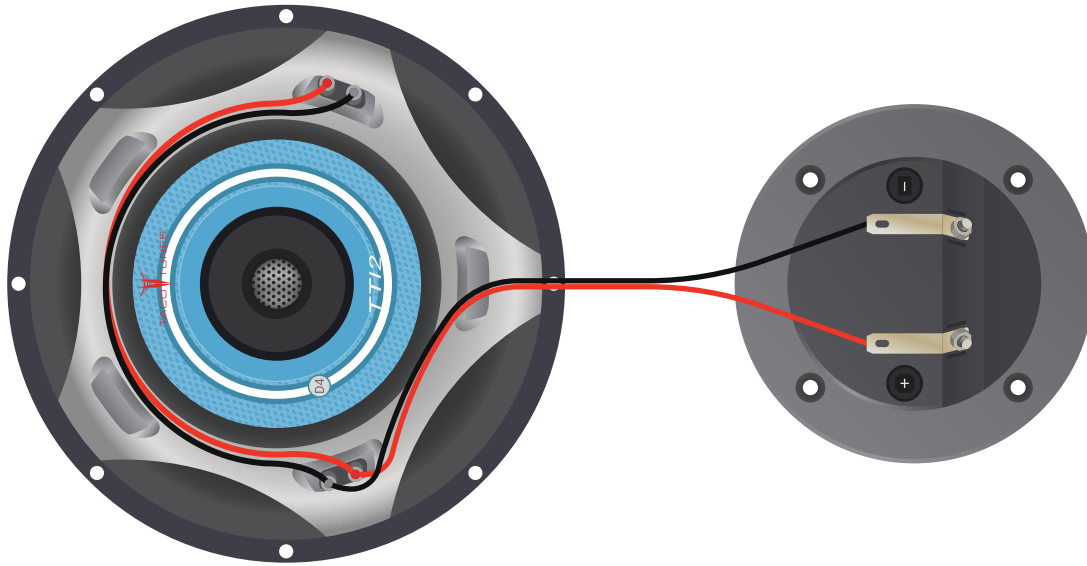

Dual Subwoofer Wiring

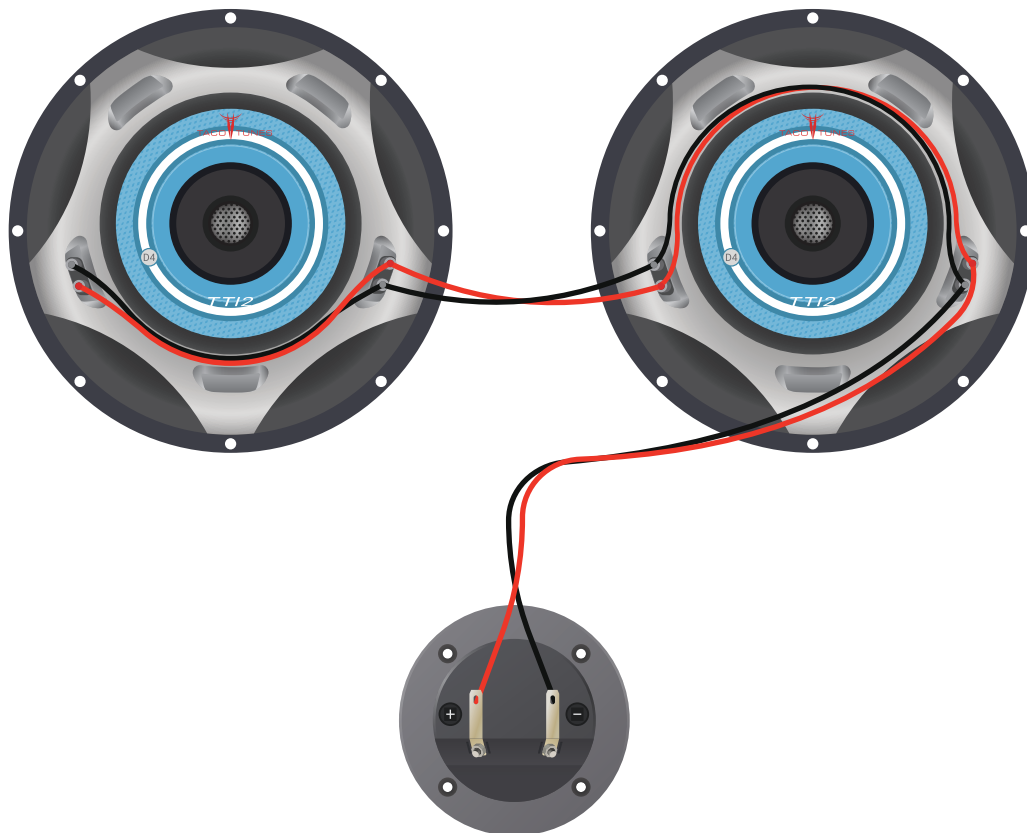

FAQ

Read below for tuning instructions

Installation steps:

Follow the installation steps for your new head unit. Most head unit setups for your Tundra will have the dash kit, maestro, head unit and other parts to get the head unit installed INTO your Tundra. However, you will need a few extra items to connect your new head unit to your Tundra.

Parts needed to connect to your existing tacotunes System 1A or System 1B:

1. In your original tacotunes amplifier boxes, we included RCA to Molex adapters. If you do not have those available, we offer them on our website.
2. You will need 3 sets of quality RCA cables. We offer them on our website. The RCAs connect from the back of your new head unit to the RCA to Molex adapters (see diagram). Please note the diagram above is a generic representation of your new head unit. Some RCA plugs are inherent to the head unit while some are connected use a harness type connection.
3. You will need roughly 15 feet of blue remote turn on wire. You must use the (BLUE/WHITE) wire or remote turn on wire on the back of your head unit to trigger the amps. **DO NOT USE** the trigger wire in your plug and play harness system. The head unit's RCA outputs will now connect to your amp(s) INPUTS. Remove the PNP harness system input signal(s front / rear & sub) and replace with the RCA to MOLEX adapters. The Black Molex plugs will remain in place. However, you will need to "re-tune" your amps to match the output coming from your head unit.

Additional amp tuning and head unit settings:

TXD3204v3

We suggest setting our TXD3204v3 FRONT & REAR filters to FULL. Set your gain per tuning instructions and then set your High Pass Filters (front & rear) on your head unit to 80Hz with a 12dB slope / roll off.

TXD10001

We suggest setting TXD10001, LPF knob to 250Hz (all way up and to the right). Set your gain per tuning instructions and then set your Low Pass Filter on your head unit to 80Hz with a 18dB slope / roll off.

IMPORTANT:

If your Tundra battery dies / is replaced many head units will LOSE these settings. Be sure to turn these filters back ON! Or you risk damaging your speakers and subwoofer(s)